

MRTech IFF SDK technical manual

Copyright © 2024 MREch SK, s.r.o.

The information provided in this documentation is believed to be accurate and reliable as of the date provided.

Revision History

Number	Date	Description	Name
1.0	February 2022	initial release	MS
1.1	March 2022	updated component descriptions	MS
1.2	May 2022	added chain control interface description	MS
1.3	January 2023	IFF SDK release v1.3	MS
1.4	August 2023	IFF SDK release v1.4	MS
1.5	September 2023	IFF SDK release v1.5	MS
1.6	October 2023	IFF SDK release v1.6	MS
1.7	December 2023	IFF SDK release v1.7	MS
1.8	July 2024	IFF SDK release v1.8	MS
1.8.1	July 2024	IFF SDK release v1.8.1	MS
1.9	December 2024	IFF SDK release v1.9	MS

Contents

1 Introduction	1
1.1 Documentation and Support	1
1.2 Contact MREch	1
2 About IFF SDK	2
2.1 System requirements	2
2.2 Basic features	2
2.3 Advantages	2
2.4 Concepts	3
3 Quick start	4
3.1 Dependencies	4
3.2 Package contents	4
3.3 Installation	4
4 IFF components	5
4.1 Sources	5
4.1.1 genicam	6
4.1.2 raw_frame_player	8
4.1.3 rtsp_source	13
4.1.4 v4l2cam	13
4.1.5 xicamera	15
4.2 Sinks	18
4.2.1 awb_aec	18
4.2.2 files_writer	23
4.2.3 frame_exporter	24
4.2.4 frames_writer	24
4.2.5 dng_writer	25
4.2.6 exr_writer	29
4.2.7 metadata_saver	32
4.2.8 rtsp_stream	33
4.3 Filters	34
4.3.1 averager	34
4.3.2 decoder	34
4.3.3 encoder	35
4.3.4 fps_limiter	38
4.3.5 frame_dropper	38

4.3.6	gamma	39
4.3.7	highlight_recovery	39
4.3.8	histogram	40
4.3.9	image_crop	41
4.3.10	metadata_exporter	42
4.3.11	packer	43
4.3.12	resizer	43
4.3.13	sub_monitor	44
4.3.14	xiprocessor	44
4.3.15	cuda_processor	45
	Import adapters	47
	import_from_device	47
	import_from_host	47
	Export adapters	47
	export_to_device	48
	export_to_host	51
	histogram	52
	Image filters	52
	bitdepth	53
	black_level	53
	color_correction	53
	crop	54
	demosaic	55
	denoise and raw_denoise	55
	exposure_indicator	56
	ffc	57
	gamma8, gamma12, gamma16	58
	huesatmap	59
	resizer	59
	undistort	59
	white_balance	60
5	IFF SDK library interface	62
5.1	Functions	62
5.1.1	iff_initialize()	62
5.1.2	iff_finalize()	62
5.1.3	iff_log()	62
5.1.4	iff_create_chain()	62
5.1.5	iff_release_chain()	63

5.1.6	<code>iff_get_params()</code>	63
5.1.7	<code>iff_set_params()</code>	63
5.1.8	<code>iff_execute()</code>	64
5.1.9	<code>iff_set_callback()</code>	64
5.1.10	<code>iff_set_export_callback()</code>	64
5.2	Structures	65
5.2.1	<code>iff_image_metadata</code>	65
5.3	Types	66
5.3.1	<code>iff_error_handler_t</code>	66
5.3.2	<code>iff_result_handler_t</code>	66
5.3.3	<code>iff_callback_t</code>	66
5.3.4	<code>iff_frame_export_function_t</code>	66
6	IFF SDK configuration	68
6.1	Initializing IFF	68
6.2	Framework configuration format	68
6.3	Chain description format	70
6.3.1	Elements	72
6.3.2	Connections	72
6.3.3	Parameter control list	72
6.3.4	Command call list	73
6.4	Input formats of controllable interface functions	73
6.4.1	Get parameters input format	73
6.4.2	Set parameters input format	73
6.4.3	Execute input format	74
6.5	Chain control via HTTP	74
6.5.1	Curl command examples	75
7	Sample applications	76
7.1	<code>farsight</code>	76
7.2	<code>imagebroker</code>	76
7.3	<code>crowsnest</code>	77
7.3.1	Installation	77
7.3.2	Deployment of modifications	77
7.4	<code>spectraprofiler</code>	77
7.5	<code>streamadapter</code>	77
7.5.1	Usage	78
7.6	<code>lensprofiler</code>	78

A Changelog	79
A.1 Version 1.9	79
A.2 Version 1.8.1	79
A.3 Version 1.8	79
A.4 Version 1.7	80
A.5 Version 1.6	80
A.6 Version 1.5	80
A.7 Version 1.4	80
A.8 Version 1.3	81
A.9 Version 1.2	81
A.10Version 1.1	81
A.11Version 1.0	81
 B License notices	 82

1 Introduction

MRTech IFF SDK provides an environment for creating image processing applications targeted for high-performance machine vision systems.

IFF SDK takes its name from Image Flow Framework (IFF) which has been developed and used by **MRTech** company for its machine vision projects since 2016.

The intended and structural purposes of the IFF SDK are to acquire, process, deliver images in the way the user wants, as efficiently as possible. With IFF SDK as MREch team believes the users can achieve maximum performance for the chosen configuration of the image processing system.

All rights to IFF SDK belong to MREch SK.

1.1 Documentation and Support

The manual explains how to install MREch IFF SDK to run it successfully.

If you have not already used IFF SDK and performed the initial setup steps, see the [Quick start](#) guide.

A detailed description of the library components, their parameters, as well as examples of how to use the SDK effectively are given in the following sections.

Note

MRTech is constantly developing IFF SDK, so the manual can be subject to change.

For more information, or if the user needs support in using IFF SDK, please contact us.

1.2 Contact MREch

MRTech SK, s.r.o.

- Web: <https://mr-technologies.com/>
- Email: support@mr-technologies.com

2 About IFF SDK

2.1 System requirements

Supported hardware platforms:

- 64-bit Intel x86 (also known as x86_64 or AMD64)
- 64-bit ARM (also known as ARM64 or AArch64)
 - main target is NVIDIA Jetson family

Supported operating systems:

- Linux
- Windows
- macOS (preliminary support)

Supported hardware acceleration devices:

- GPU
 - NVIDIA GPUs, including embedded Jetson platform, using CUDA API
- video encoding
 - discrete NVIDIA GPUs using NVENC API
 - embedded NVIDIA Jetson platform using V4L API
- video decoding
 - discrete NVIDIA GPUs using NVDEC API

2.2 Basic features

- Textual description of pipeline configuration that allows user to create image processing workflows of any complexity.
- A wide range of processing modules (e.g. demosaicing, video encoding) working out-of-the-box.
- Ability to export and import images from the SDK pipeline to the customer application.
- Control of pipeline parameters at runtime.
- Easy integration with OpenCV, third-party processing libraries, custom processing modules.
- Hardware and software accelerated image processing on NVIDIA GPUs.

2.3 Advantages

- Production-ready, high-quality code, successfully used in many projects.
- High-performance image processing with low latency and low overhead.
- SDK architecture, that makes it easy to develop and customize the target application.
- Technical support, consulting, assistance from MRTech in implementation (when necessary).

2.4 Concepts

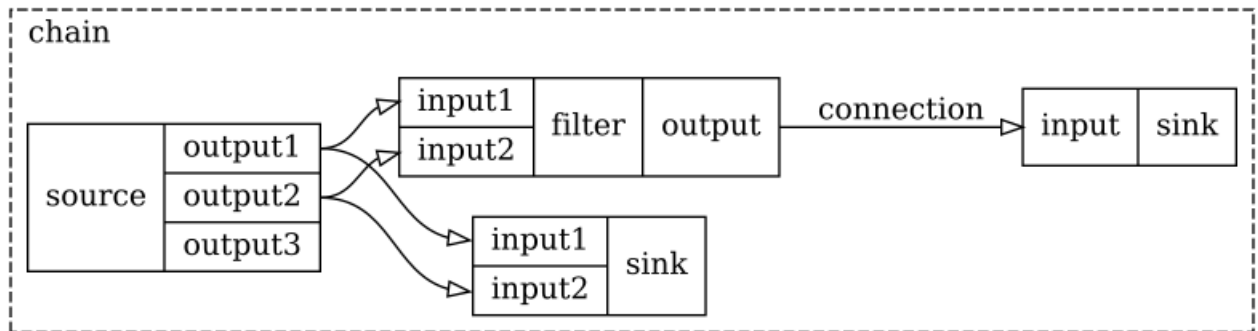

Figure 1: Pipeline

- IFF SDK purpose is to create and manage an image processing pipeline based on clear-text description in JSON format.
- Pipeline consists of one or more chains and images passing through them.
- Each chain is a directed acyclic graph defined by a list of elements and connections between their inputs and outputs.
- Element is an instantiation of specific IFF SDK component implementing some function (e.g. video encoding).
- Each component has a specific list of parameters, commands and callbacks.
- Element can have any number (zero or more) of inputs and outputs, defined by its type (component name) and configuration (parameters).
- Connection specifies that images from an output of one element will be passed to an input of another element.
- There must be exactly one connection per each existing input in a chain.
- Output on the other hand can be a source of any number (zero or more) of connections.
- Images are queued at inputs of elements and are dropped if queue exceeds the size specified in element parameters.
- Each image is defined by its metadata and a buffer (memory pointer) residing in some device (CPU or GPU RAM).
- All needed buffers are pre-allocated once pipeline parameters are determined, so out of memory situation is detected early.

3 Quick start

3.1 Dependencies

1. For CUDA edition: [NVIDIA GPU drivers](#)
2. For GenICam edition: camera vendor drivers and GenTL producer library, for example:
 - a. [pylon Camera Software Suite](#) from Basler
 - b. [Arena SDK](#) from LUCID
3. For XIMEA edition: [XIMEA software package](#)

3.2 Package contents

1. documentation - this manual
2. samples - example source code from [Sample applications](#)
3. sdk - MREch IFF SDK
 - a. include - C header file
 - b. lib - shared libraries
 - c. licenses_3rdparty - license texts of third party software used by IFF SDK
4. version.txt - release number and edition information

3.3 Installation

1. Install packages listed in [Dependencies](#).
2. Unpack the MREch IFF SDK package.
3. Build a sample:
 - on Linux or in Windows developer shell:

```
cd samples/01_streaming
mkdir build
cd build
cmake ..
cmake --build .
```
 - in Microsoft Visual Studio: open samples/01_streaming folder and build as usual.
4. Edit configuration file farsight.json in samples/01_streaming/build/bin directory:
 - replace <CHANGEME> strings with correct values (IP address and camera serial number);
 - on Jetson change NV12_BT709 to YV12_BT709 as indicated by the inline comment;
 - adjust other settings, if you'd like.
5. Run the sample:
 - on Linux:

```
cd bin
./farsight
```
 - on Windows: execute farsight.exe in samples/01_streaming/build/bin directory.

4 IFF components

There are three kinds of IFF components: sources, sinks and filters.

Any kind of components shares two interfaces:

- `element` - this interface gives component an ability to be chained e.g. linked into processing chain
- `controllable` - an interface which gives an ability components parameters to be controlled in run-time

All components have following common parameters:

```
1 {
2   "id": "comp_id",
3   "type": "comp_type",
4   "max_processing_count": 2
5 }
```

- `id`: ID of the component. Must be unique within given processing chain.
- `type`: type of the component (e.g. `xicamera`, `rtsp_stream`, `rtsp_source`, e.t.c.)
- `max_processing_count` (default 2): maximum number of frames that can be simultaneously processed by given instance of the component

4.1 Sources

Components of this kind inject data into the processing chain. They have no inputs, but only outputs. So this kind of component should be the initial element of the processing chain.

Common parameters for all sources are:

```
1 {
2   "dispatch_control_mode": "subscription",
3   "trigger_mode": {
4     "mode": "free_run",
5     "line": 0
6   }
7 }
```

- `dispatch_control_mode` (default "subscription"): start/stop dispatching mode, one of the following values:
 - `subscription` (default) - automatically start dispatching when first consumer subscribed and stop when last consumer unsubscribed
 - `command` - explicitly start/stop dispatching by corresponding commands
- `trigger_mode`:
 - `mode` (default "free_run"): trigger mode, one of the following values:
 - * `free_run` (default) - new frames are dispatched automatically
 - * `software` - new frame is dispatched by trigger command
 - * `hardware_rising` - new frame is dispatched when rising signal is detected on camera hardware trigger line

- * `hardware_falling` - new frame is dispatched when rising signal is detected on camera hardware trigger line
- `line` (default 0): camera hardware trigger line number, only used for hardware trigger mode

Any source also supports the following two commands:

- `start` - makes source start dispatch images
- `stop` - makes source stop dispatch images
- `trigger` - makes source dispatch an image, if it's in software trigger mode

See `iff_execute()` for more details on command execution by elements.

4.1.1 genicam

GenICam camera.

JSON configuration:

```

1 {
2     "id": "cam",
3     "type": "genicam",
4     "max_processing_count": 2,
5     "dispatch_control_mode": "subscription",
6     "cpu_device_id": "cpu_dev",
7     "producer": "/opt/pylon/lib/gentlproducer/gtl/ProducerU3V.cti",
8     "serial_number": "23096645",
9     "max_open_retries": -1,
10    "wait_after_error_sec": 3,
11    "use_alloc": false,
12    "max_buffers_queue_size": 2,
13    "min_buffers_queue_size": 1,
14    "image_capture_timeout": 5000,
15    "pixel_format": "BayerRG12p",
16    "roi_region": {
17        "offset_x": 0,
18        "offset_y": 0,
19        "width": 1920,
20        "height": 1080
21    },
22    "custom_params": [
23        { "DeviceLinkThroughputLimitMode": "On" },
24        { "DeviceLinkThroughputLimit": 400000000 }
25    ],
26    "black_level": 0,
27    "exposure": 10000,
28    "gain": 0.0,
29    "fps": 0.0,
30    "auto_white_balance": false,
31    "wb": {
32        "dcp_file": "color_profile.dcp",
33        "temperature": 5003,
34        "r": 1.0,
35        "g1": 1.0,
36        "g2": 1.0,
37        "b": 1.0,

```

```

38     "r_off": 0,
39     "g_off": 0,
40     "b_off": 0
41 }
42 }

```

parameters

- `cpu_device_id`: CPU device ID
- `producer`: path to GenTL producer library (usually comes with the camera vendor's software package), for example:
 - Basler:
 - * Ethernet cameras:
 - `/opt/pylon/lib/gentlproducer/gtl/ProducerGEV.cti` - Linux
 - `C:/Program Files/Basler/pylon 7/Runtime/x64/ProducerGEV.cti` - Windows
 - * USB cameras:
 - `/opt/pylon/lib/gentlproducer/gtl/ProducerU3V.cti` - Linux
 - `C:/Program Files/Basler/pylon 7/Runtime/x64/ProducerU3V.cti` - Windows
 - LUCID (on Linux replace `/path/to/` with path to the directory, where Arena SDK package was unpacked):
 - * `/path/to/ArenaSDK_Linux_ARM64/lib/GenTL_LUCID.cti` - Linux ARM64
 - * `/path/to/ArenaSDK_Linux_x64/lib64/GenTL_LUCID.cti` - Linux x86_64
 - * `C:/Program Files/Lucid Vision Labs/Arena SDK/x64Release/GenTL_LUCID_v140.cti` - Windows
 - XIMEA:
 - * legacy cameras (FireWire, USB 2, older USB 3 camera families, like xiD and xiQ):
 - `/opt/XIMEA/lib/ximea.gentl.cti` - Linux
 - `C:/XIMEA/GenTL Producer/ximea.gentl.cti` - Windows
 - * modern cameras (PCIe, newer USB 3 camera families, like xiC and xiJ):
 - `/opt/XIMEA/lib/ximea.gentl2.cti` - Linux
 - `C:/XIMEA/GenTL Producer/ximea.gentl2.cti` - Windows
- `serial_number`: serial number of GenICam camera
- `max_open_retries` (default -1): the maximum number of retries to open the camera before giving up (and transitioning to the disconnected state), negative value means unlimited
- `wait_after_error_sec` (default 3): time in seconds between attempts to open the camera
- `use_alloc` (default false): whether to allocate buffers using `DSAllocAndAnnounceBuffer` GenTL producer function
- `max_buffers_queue_size` (default 2): maximum number of buffers to keep in acquisition queue
- `min_buffers_queue_size` (default `max_buffers_queue_size-1`): minimum number of buffers to keep in acquisition queue
- `image_capture_timeout` (default 5000): get image timeout in milliseconds
- `pixel_format`: camera output GenICam image pixel format
- `roi_region` (optional): camera ROI, not modified by default
- `custom_params` (optional): array of custom GenICam camera parameters, for example:
 - Basler:
 - * `{ "BslColorSpace": "0ff" }` - disables gamma correction, making acquired images linear, as expected for raw (e.g. Bayer) pixel formats
- `black_level` (default 0): fallback black level, used only in case GenTL producer doesn't provide it

- exposure (default 10000): camera exposure in microseconds, can be modified at runtime
- gain (default 0.0): camera gain in dB, can be modified at runtime
- fps (default 0.0): camera FPS limit, zero means unlimited (free run), can be modified at runtime
- auto_white_balance (default false): enable GenICam camera auto white balance, can be modified at runtime
- wb (optional): white balance settings, can be modified at runtime, can be specified in the following two ways (in order of precedence):
 - using color temperature:
 - * dcp_file: path to DNG color profile file
 - * temperature (default 5003): white balance temperature in kelvins
 - using white balance coefficients:
 - * r, g1, g2, b (default 1.0): white balance gains for four Bayer channels (red, first green, second green, blue)
 - * g: alternative way to specify both g1 and g2 at the same time, if they are equal (g1 and g2 take priority over this setting)
 - * r_off, g1_off, g2_off, b_off (default 0): offsets for histogram stretch white balance algorithm (rarely used) for four Bayer channels (red, first green, second green, blue)
 - * g_off: alternative way to specify both g1_off and g2_off at the same time, if they are equal (g1_off and g2_off take priority over this setting)

4.1.2 raw_frame_player

Reads all image files from specified directory and dispatches them to subscribers with given FPS.

JSON configuration:

```

1 {
2   "id": "reader",
3   "type": "raw_frame_player",
4   "dispatch_control_mode": "subscription",
5   "trigger_mode": {
6     "mode": "free_run"
7   },
8   "cpu_device_id": "cpu_dev",
9   "directory": "/path/to/frames/directory",
10  "offset": 0,
11  "width": 2048,
12  "height": 2048,
13  "padding": 0,
14  "format": "BayerRG8",
15  "fps": 30.0,
16  "loop_images": false,
17  "io_timer_interval": 10,
18  "max_cached_images_count": 2,
19  "wb": {
20    "dcp_file": "color_profile.dcp",
21    "temperature": 5003,
22    "r": 1.0,
23    "g1": 1.0,
24    "g2": 1.0,
25    "b": 1.0,
26    "r_off": 0,
27    "g_off": 0,
28    "b_off": 0
  }
}

```

```

29     },
30     "filename_template": "{sequence_number:06}.raw",
31     "template_params": {
32         "aperture": 1.4
33     },
34     "metadata": [
35     ]
36 }

```

parameters

- `cpu_device_id`: CPU device ID
- `directory`: path to target directory
- `offset` (default 0): offset in bytes of image data stored in files
- `width`: width in pixels of images stored in files
- `height`: height in pixels of images stored in files
- `padding` (default 0): row padding in bytes of images stored in files
- `format`: pixel format of images stored in files, see [supported formats](#) below
- `fps` (default 30.0): desired dispatch FPS
- `loop_images` (default false): dispatch all images from target directory just once or in infinite loop
- `io_timer_interval` (default 10): file I/O status update interval in milliseconds
- `max_cached_images_count` (default 2): maximum number of preloaded images to store in memory, zero means that image is loaded at the time of dispatch
- `wb` (optional): white balance settings, can be modified at runtime, can be specified in the following two ways (in order of precedence):
 - using color temperature:
 - * `dcp_file`: path to DNG color profile file
 - * `temperature` (default 5003): white balance temperature in kelvins
 - using white balance coefficients:
 - * `r`, `g1`, `g2`, `b` (default 1.0): white balance gains for four Bayer channels (red, first green, second green, blue)
 - * `g`: alternative way to specify both `g1` and `g2` at the same time, if they are equal (`g1` and `g2` take priority over this setting)
 - * `r_off`, `g1_off`, `g2_off`, `b_off` (default 0): offsets for histogram stretch white balance algorithm (rarely used) for four Bayer channels (red, first green, second green, blue)
 - * `g_off`: alternative way to specify both `g1_off` and `g2_off` at the same time, if they are equal (`g1_off` and `g2_off` take priority over this setting)
- `filename_template` (optional): string in [{fmt} library format](#) to use as filename template, refer to description of this parameter for [frames_writer](#)
- `template_params` (optional): additional static parameters (string or number) for `filename_template`
- `metadata` (optional): metadata as returned by [metadata_saver](#), must be present, if `filename_template` parameter is specified

special parameters

- `total_images` (read only): total number of images found by `raw_frame_player` in the specified directory

If both `filename_template` and `metadata` parameters are specified frames are dispatched with recorded metadata except for the following fields:

- white balance settings;
- sequence ID;
- src_ts timestamp after the first loop over all files (if loop_images is true).

Note

Hardware trigger mode is not available for raw_frame_player component. Common max_processing_count parameter is also ignored, max_cached_images_count parameter is to be used instead with similar meaning.

supported formats

- Mono8 - Monochrome 8-bit
- Mono9 - Monochrome 9-bit unpacked
- Mono10 - Monochrome 10-bit unpacked
- Mono11 - Monochrome 11-bit unpacked
- Mono12 - Monochrome 12-bit unpacked
- Mono13 - Monochrome 13-bit unpacked
- Mono14 - Monochrome 14-bit unpacked
- Mono15 - Monochrome 15-bit unpacked
- Mono16 - Monochrome 16-bit
- Mono9p - Monochrome 9-bit packed
- Mono10p - Monochrome 10-bit packed
- Mono11p - Monochrome 11-bit packed
- Mono12p - Monochrome 12-bit packed
- Mono13p - Monochrome 13-bit packed
- Mono14p - Monochrome 14-bit packed
- Mono15p - Monochrome 15-bit packed
- RGB8 - Red-Green-Blue 8-bit
- RGB9 - Red-Green-Blue 9-bit unpacked
- RGB10 - Red-Green-Blue 10-bit unpacked
- RGB11 - Red-Green-Blue 11-bit unpacked
- RGB12 - Red-Green-Blue 12-bit unpacked
- RGB13 - Red-Green-Blue 13-bit unpacked
- RGB14 - Red-Green-Blue 14-bit unpacked
- RGB15 - Red-Green-Blue 15-bit unpacked
- RGB16 - Red-Green-Blue 16-bit
- BGR8 - Blue-Green-Red 8-bit
- BGR9 - Blue-Green-Red 9-bit unpacked
- BGR10 - Blue-Green-Red 10-bit unpacked
- BGR11 - Blue-Green-Red 11-bit unpacked
- BGR12 - Blue-Green-Red 12-bit unpacked
- BGR13 - Blue-Green-Red 13-bit unpacked
- BGR14 - Blue-Green-Red 14-bit unpacked

- BGR15 - Blue-Green-Red 15-bit unpacked
- BGR16 - Blue-Green-Red 16-bit
- RGBA8 - Red-Green-Blue-Alpha 8-bit
- RGBA9 - Red-Green-Blue-Alpha 9-bit unpacked
- RGBA10 - Red-Green-Blue-Alpha 10-bit unpacked
- RGBA11 - Red-Green-Blue-Alpha 11-bit unpacked
- RGBA12 - Red-Green-Blue-Alpha 12-bit unpacked
- RGBA13 - Red-Green-Blue-Alpha 13-bit unpacked
- RGBA14 - Red-Green-Blue-Alpha 14-bit unpacked
- RGBA15 - Red-Green-Blue-Alpha 15-bit unpacked
- RGBA16 - Red-Green-Blue-Alpha 16-bit
- BGRA8 - Blue-Green-Red-Alpha 8-bit
- BGRA9 - Blue-Green-Red-Alpha 9-bit unpacked
- BGRA10 - Blue-Green-Red-Alpha 10-bit unpacked
- BGRA11 - Blue-Green-Red-Alpha 11-bit unpacked
- BGRA12 - Blue-Green-Red-Alpha 12-bit unpacked
- BGRA13 - Blue-Green-Red-Alpha 13-bit unpacked
- BGRA14 - Blue-Green-Red-Alpha 14-bit unpacked
- BGRA15 - Blue-Green-Red-Alpha 15-bit unpacked
- BGRA16 - Blue-Green-Red-Alpha 16-bit
- BayerRG8 - Bayer Red-Green 8-bit
- BayerRG9 - Bayer Red-Green 9-bit unpacked
- BayerRG10 - Bayer Red-Green 10-bit unpacked
- BayerRG11 - Bayer Red-Green 11-bit unpacked
- BayerRG12 - Bayer Red-Green 12-bit unpacked
- BayerRG13 - Bayer Red-Green 13-bit unpacked
- BayerRG14 - Bayer Red-Green 14-bit unpacked
- BayerRG15 - Bayer Red-Green 15-bit unpacked
- BayerRG16 - Bayer Red-Green 16-bit
- BayerBG8 - Bayer Blue-Green 8-bit
- BayerBG9 - Bayer Blue-Green 9-bit unpacked
- BayerBG10 - Bayer Blue-Green 10-bit unpacked
- BayerBG11 - Bayer Blue-Green 11-bit unpacked
- BayerBG12 - Bayer Blue-Green 12-bit unpacked
- BayerBG13 - Bayer Blue-Green 13-bit unpacked
- BayerBG14 - Bayer Blue-Green 14-bit unpacked
- BayerBG15 - Bayer Blue-Green 15-bit unpacked
- BayerBG16 - Bayer Blue-Green 16-bit
- BayerGR8 - Bayer Green-Red 8-bit
- BayerGR9 - Bayer Green-Red 9-bit unpacked
- BayerGR10 - Bayer Green-Red 10-bit unpacked
- BayerGR11 - Bayer Green-Red 11-bit unpacked
- BayerGR12 - Bayer Green-Red 12-bit unpacked

- BayerGR13 - Bayer Green-Red 13-bit unpacked
- BayerGR14 - Bayer Green-Red 14-bit unpacked
- BayerGR15 - Bayer Green-Red 15-bit unpacked
- BayerGR16 - Bayer Green-Red 16-bit
- BayerGB8 - Bayer Green-Blue 8-bit
- BayerGB9 - Bayer Green-Blue 9-bit unpacked
- BayerGB10 - Bayer Green-Blue 10-bit unpacked
- BayerGB11 - Bayer Green-Blue 11-bit unpacked
- BayerGB12 - Bayer Green-Blue 12-bit unpacked
- BayerGB13 - Bayer Green-Blue 13-bit unpacked
- BayerGB14 - Bayer Green-Blue 14-bit unpacked
- BayerGB15 - Bayer Green-Blue 15-bit unpacked
- BayerGB16 - Bayer Green-Blue 16-bit
- BayerRG9p - Bayer Red-Green 9-bit packed
- BayerRG10p - Bayer Red-Green 10-bit packed
- BayerRG11p - Bayer Red-Green 11-bit packed
- BayerRG12p - Bayer Red-Green 12-bit packed
- BayerRG13p - Bayer Red-Green 13-bit packed
- BayerRG14p - Bayer Red-Green 14-bit packed
- BayerRG15p - Bayer Red-Green 15-bit packed
- BayerBG9p - Bayer Blue-Green 9-bit packed
- BayerBG10p - Bayer Blue-Green 10-bit packed
- BayerBG11p - Bayer Blue-Green 11-bit packed
- BayerBG12p - Bayer Blue-Green 12-bit packed
- BayerBG13p - Bayer Blue-Green 13-bit packed
- BayerBG14p - Bayer Blue-Green 14-bit packed
- BayerBG15p - Bayer Blue-Green 15-bit packed
- BayerGR9p - Bayer Green-Red 9-bit packed
- BayerGR10p - Bayer Green-Red 10-bit packed
- BayerGR11p - Bayer Green-Red 11-bit packed
- BayerGR12p - Bayer Green-Red 12-bit packed
- BayerGR13p - Bayer Green-Red 13-bit packed
- BayerGR14p - Bayer Green-Red 14-bit packed
- BayerGR15p - Bayer Green-Red 15-bit packed
- BayerGB9p - Bayer Green-Blue 9-bit packed
- BayerGB10p - Bayer Green-Blue 10-bit packed
- BayerGB11p - Bayer Green-Blue 11-bit packed
- BayerGB12p - Bayer Green-Blue 12-bit packed
- BayerGB13p - Bayer Green-Blue 13-bit packed
- BayerGB14p - Bayer Green-Blue 14-bit packed
- BayerGB15p - Bayer Green-Blue 15-bit packed
- YV12 - 8-bit planar YVU 4:2:0 subsampling
- I420_10LE - 10-bit planar YUV 4:2:0 subsampling
- NV12 - 8-bit semi-planar YUV 4:2:0 subsampling
- P010_10LE - 10-bit semi-planar YUV 4:2:0 subsampling

For format description see [GenICam Pixel Format Naming Convention \(PFNC\) Version 2.4](#) and [YUV formats](#) section of `export_to_device cuda_processor filter` documentation.

4.1.3 rtsp_source

Receives data over the network via RTSP (RFC 2326).

JSON configuration:

```
1 {
2   "id": "cam",
3   "type": "rtsp_source",
4   "dispatch_control_mode": "subscription",
5   "cpu_device_id": "cpu_dev",
6   "url": "rtsp://192.168.55.1:8554/cam",
7   "media_type": "video",
8   "transport": "udp",
9   "reconnect_delay_sec": 1
10 }
```

parameters

- `cpu_device_id`: CPU device ID
- `url`: RTSP resource URL
- `media_type` (default "video"): media type of the stream
- `transport` (default "udp"): transport protocol for receiving media stream, one of the following values:
 - tcp
 - udp (default)
- `reconnect_delay_sec` (default 1): time in seconds to wait before trying to reconnect after connection is lost

Note

Common `max_processing_count` and `trigger_mode` parameters along with `trigger` command are ignored by `rtsp_source` component.

4.1.4 v4l2cam

Video4Linux2 camera.

JSON configuration:

```
1 {
2   "id": "cam",
3   "type": "v4l2cam",
4   "max_processing_count": 2,
5   "dispatch_control_mode": "subscription",
6   "cpu_device_id": "cpu_dev",
7   "v4l2_device": "/dev/video0",
8   "max_open_retries": -1,
9   "wait_after_error_sec": 3,
10  "preallocate_buffers": 0,
11  "min_buffers_queue_size": 1,
12  "sensor_mode": 1,
13  "pixel_format": "",
14  "width": 3840,
15  "height": 2160,
```

```

16     "custom_params" : [
17         { "override_enable": 1 },
18         { "bypass_mode": 0 }
19     ],
20     "black_level": 0,
21     "exposure": 10000,
22     "fps": 60.0,
23     "gain": 0.0,
24     "linear_gain": false,
25     "wb": {
26         "dcp_file": "color_profile.dcp",
27         "temperature": 5003,
28         "r": 1.0,
29         "g1": 1.0,
30         "g2": 1.0,
31         "b": 1.0,
32         "r_off": 0,
33         "g_off": 0,
34         "b_off": 0
35     }
36 }

```

parameters

- `cpu_device_id`: CPU device ID
- `v4l2_device`: Linux device name corresponding to this camera
- `max_open_retries` (default -1): the maximum number of retries to open the camera before giving up (and transitioning to the disconnected state), negative value means unlimited
- `wait_after_error_sec` (default 3): time in seconds between attempts to open the camera
- `preallocate_buffers` (default 0): use `VIDIOC_REQBUFS` to preallocate specified number of buffers if not zero, otherwise use `VIDIOC_CREATE_BUFS` to allocate buffers dynamically, recommended value:
 - MIPI and GMSL cameras on NVIDIA Jetson - sum of `max_processing_count` settings of this `v4l2cam` element and all elements directly connected to its output (default zero value causes increased CPU load and latency)
 - other cameras - default zero value should work fine in most cases, but formula above can still be used when in doubt
- `min_buffers_queue_size` (default 1): minimum number of buffers kept in the device queue, should be less than `max_processing_count`
- `sensor_mode` (optional): sensor mode for camera, not modified by default
- `pixel_format` (optional): FourCC image format to request when setting camera format, not modified by default
- `width` (optional): frame width to request when setting camera format, not modified by default
- `height` (optional): frame height to request when setting camera format, not modified by default
- `custom_params` (optional): array of custom camera control parameters, names can be looked up in `v4l2-ctl -l` output, for example:
 - MIPI and GMSL cameras on NVIDIA Jetson:
 - * `{ "override_enable": 1 }` - ensures correct synchronization of settings (like exposure and gain) between camera and OS
 - * `{ "bypass_mode": 0 }` - restores image acquisition through Video4Linux2 interface in case libargus applications (utilizing NVIDIA hardware ISP) were used in the same boot session

- `black_level` (default 0): sensor black level to use in image metadata (scaled accordingly to output image format bit-depth)
- `exposure` (optional): camera exposure in microseconds, not modified by default
- `fps` (optional): camera FPS limit, not modified by default
- `gain` (optional): camera gain in dB, not modified by default
- `linear_gain` (default false): whether Video4Linux camera gain control is in linear scale and has to be converted to logarithmic dB values
- `wb` (optional): white balance settings, can be modified at runtime, can be specified in the following two ways (in order of precedence):
 - using color temperature:
 - * `dcp_file`: path to DNG color profile file
 - * `temperature` (default 5003): white balance temperature in kelvins
 - using white balance coefficients:
 - * `r`, `g1`, `g2`, `b` (default 1.0): white balance gains for four Bayer channels (red, first green, second green, blue)
 - * `g`: alternative way to specify both `g1` and `g2` at the same time, if they are equal (`g1` and `g2` take priority over this setting)
 - * `r_off`, `g1_off`, `g2_off`, `b_off` (default 0): offsets for histogram stretch white balance algorithm (rarely used) for four Bayer channels (red, first green, second green, blue)
 - * `g_off`: alternative way to specify both `g1_off` and `g2_off` at the same time, if they are equal (`g1_off` and `g2_off` take priority over this setting)

No camera controls or parameters (like selected pixel format) are modified unless specified in configuration. They are persistent until reboot or kernel driver reload and can be set using external tools like `v4l2-ctl`. Possible values and combinations of `pixel_format`, `width` and `height` can be looked up in `v4l2-ctl --list-formats-ext` output.

Note

Trigger-related common parameters and command aren't supported by `v4l2_camera` component.

4.1.5 xicamera

XIMEA camera.

JSON configuration:

```

1 {
2     "id": "cam",
3     "type": "xicamera",
4     "max_processing_count": 2,
5     "dispatch_control_mode": "subscription",
6     "trigger_mode": {
7         "mode": "free_run",
8         "line": 0
9     },
10    "cpu_device_id": "cpu_dev",
11    "serial_number": "XECAS1930002",
12    "debug_level": "WARNING",
13    "auto_bandwidth_calculation": true,
14    "image_format": "RAW8",
15    "switch_red_and_blue": false,
16    "max_open_retries": -1,

```

```

17     "wait_after_error_sec": 3,
18     "roi_region": {
19         "offset_x": 0,
20         "offset_y": 0,
21         "width": 1920,
22         "height": 1080
23     },
24     "custom_params": [
25         { "bpc": 1 },
26         { "column_fpn_correction": 1 },
27         { "row_fpn_correction": 1 },
28         { "column_black_offset_correction": 1 },
29         { "row_black_offset_correction": 1 }
30     ],
31     "buffer_mode": "safe",
32     "proc_num_threads": 0,
33     "image_capture_timeout": 5000,
34     "ts_offset": 0,
35     "exposure_offset": -1,
36     "exposure": 10000,
37     "gain": 0.0,
38     "fps": 0.0,
39     "aperture": 0.0,
40     "auto_wb": false,
41     "wb": {
42         "dcp_file": "color_profile.dcp",
43         "temperature": 5003,
44         "r": 1.0,
45         "g1": 1.0,
46         "g2": 1.0,
47         "b": 1.0,
48         "r_off": 0,
49         "g_off": 0,
50         "b_off": 0
51     }
52 }

```

parameters

- `cpu_device_id`: CPU device ID
- `serial_number`: serial number of XIMEA camera
- `debug_level` (default "WARNING"): xiAPI debug level, one of the following values:
 - DETAIL
 - TRACE
 - WARNING (default)
 - ERROR
 - FATAL
 - DISABLED
- `auto_bandwidth_calculation` (default true): whether to enable auto bandwidth calculation in xiAPI
- `image_format` (default "RAW8"): camera output **xiAPI image data format**, one of the following:
 - MON08
 - MON016

- RAW8 (default)
- RAW16
- RGB24
- RGB32
- RGB48
- RGB64
- TRANSPORT_DATA
- `switch_red_and_blue` (default false): whether to assume RGB output channel order instead of xiAPI default BGR, should be used together with accordingly set `ccMTX*` parameters in `custom_params` section
- `max_open_retries` (default -1): the maximum number of retries to open the camera before giving up (and transitioning to the disconnected state), negative value means unlimited
- `wait_after_error_sec` (default 3): time in seconds between attempts to open the camera
- `roi_region` (optional): camera ROI, by default full frame is used
- `custom_params` (optional): array of custom camera [parameters from xiAPI](#)
- `buffer_mode` (default "safe"): "unsafe" setting together with `image_format` set to "TRANSPORT_DATA" avoids copying the image from xiAPI and returned data pointer is used directly instead
- `proc_num_threads` (default 0): number of threads per image processor (if value is zero or negative auto-detected default is used)
- `image_capture_timeout` (default 5000): get image timeout in milliseconds
- `ts_offset` (default 0): camera timestamp offset, which will be subtracted from reported value
- `exposure_offset` (default -1): correction for reported exposure time, -1 means auto-detect
- `exposure` (default 10000): camera exposure in microseconds, can be modified at runtime
- `gain` (default 0.0): camera gain in dB, can be modified at runtime
- `fps` (default 0.0): camera FPS limit, zero means unlimited (free run), can be modified at runtime
- `aperture` (default 0.0): lens aperture, zero means do not enable lens control, can be modified at runtime
- `auto_wb` (default false): enable xiAPI auto white balance, has no effect if `image_format` is set to TRANSPORT_DATA, can be modified at runtime
- `wb` (optional): white balance settings, can be modified at runtime, can be specified in the following two ways (in order of precedence):
 - using color temperature:
 - * `dcp_file`: path to DNG color profile file
 - * `temperature` (default 5003): white balance temperature in kelvins
 - using white balance coefficients:
 - * `r`, `g1`, `g2`, `b` (default 1.0): white balance gains for four Bayer channels (red, first green, second green, blue)
 - * `g`: alternative way to specify both `g1` and `g2` at the same time, if they are equal (`g1` and `g2` take priority over this setting)
 - * `r_off`, `g1_off`, `g2_off`, `b_off` (default 0): offsets for histogram stretch white balance algorithm (rarely used) for four Bayer channels (red, first green, second green, blue)
 - * `g_off`: alternative way to specify both `g1_off` and `g2_off` at the same time, if they are equal (`g1_off` and `g2_off` take priority over this setting)

4.2 Sinks

Components of this kind are the final consumers of data in the processing chain. They have no outputs, but only inputs. Thus, it should be one of the terminal links in the processing chain.

Common parameter for all sinks is:

```
1 {
2   "autostart": false
3 }
```

- `autostart` (default `false`): if set to `true`, sink component will allow data to be dispatched to it as soon as the image parameters are received

Any sink also supports the following two commands:

- `on` - makes sink start processing images
- `off` - makes sink stop processing images

See [`iff_execute\(\)`](#) for more details on command execution by elements.

Any sink has those two callbacks:

- `on_started` - called when the sink is turned on
- `on_stopped` - called when the sink is turned off

Both of these callbacks return empty JSON. See [`iff_set_callback\(\)`](#) for information on how to set callback for an element.

4.2.1 `awb_aec`

Sets white balance and exposure based on the image histogram.

JSON configuration:

```
1 {
2   "id": "ctrl",
3   "type": "awb_aec",
4   "max_processing_count": 2,
5   "autostart": false,
6   "cpu_device_id": "cpu_dev",
7   "aec_enabled": false,
8   "awb_enabled": false,
9   "noise_floor": 0.01,
10  "saturation": 0.987,
11  "min_area": 0.01,
12  "wb_stretch": false,
13  "wb_ratio_under": 0.0,
14  "wb_ratio_over": 1.0,
15  "wb_margin_under": 0.0,
16  "wb_margin_over": 0.0,
17  "wb_comp_min": 0.0,
18  "wb_comp_max": 1.0,
19  "ctrl_latency": 3,
20  "add_frames": 0,
```

```

21  "min_exposure": 100,
22  "max_exposure": 0,
23  "min_gain": 0.0,
24  "max_gain": 0.0,
25  "gain_step": 1.0,
26  "gain_priority": 0.5,
27  "exposure_margin": 0.05,
28  "hdr_threshold_low": 1.0,
29  "hdr_threshold_high": 1.0,
30  "ev_correction": 0.0,
31  "hdr_median_ev": -3.0
32  }

```

formula

$$whitepoint = bins - 1$$

where $bins$ is number of bins in input histogram

$$total_i = \sum_j in_{ij}$$

$$sum_i = \sum_j in_{ij} \cdot j$$

$i \in \{R, G, B\}$ or $i \in \{R, G1, G2, B\}$ depending on input histogram format

$j \in I$

$$I = \{0, 1, 2, \dots, whitepoint\}$$

$$m = \arg \max \frac{sum_i}{total_i} \quad (a)$$

(a) selects color channel with the highest mean value.

simple white balance

The most simple approach to auto white balance is to scale each color channel so that their mean values match (it works well when so called gray world assumption holds). For that the most bright (with the highest mean value) channel is left unscaled and calculated gains are applied to the remaining ones.

$$threshold = saturation \cdot (whitepoint - black_level) + black_level$$

where $black_level$ is taken from input histogram metadata

$$saturated_i = \sum_{j \geq threshold} in_{ij}$$

$$green_factor_i = \begin{cases} 2 & i = G \\ 1 & \text{otherwise} \end{cases}$$

$$sat_cnt = \max \frac{saturated_i}{green_factor_i}$$

$$O_i = \{x \in I \mid \sum_{j \geq x} in_{ij} \leq sat_cnt \cdot green_factor_i\} \cup \{bins\}$$

$$cut_i = \min_{x \in O_i} x$$

$$cnt_cut_i = \sum_{j \geq cut_i} in_{ij}$$

$$corr_i = (sat_cnt \cdot green_factor_i - cnt_cut_i) \cdot (cut_i - 1) + \sum_{j \geq cut_i} in_{ij} \cdot j$$

$$sum_corr_i = sum_i - corr_i$$

$$total_corr_i = total_i - sat_cnt \cdot green_factor_i$$

$$m_corr = \arg \max \frac{sum_corr_i}{total_corr_i}$$

$$noise_level = \min \frac{sum_corr_i}{total_corr_i} - black_level$$

$$out_off_i = 0$$

$$out_gain_i = \begin{cases} in_gain_i & total_R - sat_cnt \leq min_area \cdot total_R \\ in_gain_i & noise_level \leq noise_floor \cdot (whitepoint - black_level) \\ \frac{\frac{sum_corr_{m_corr}}{total_corr_{m_corr}} - black_level}{\frac{sum_corr_i}{total_corr_i} - black_level} & \text{otherwise} \end{cases}$$

histogram stretch white balance

This is a custom auto white balance algorithm aimed at better quality video encoding for streaming of hazy images and to be reverted on the receiving end.

$$comp_range = wb_comp_max - wb_comp_min$$

$$q_under_i = \min_{x \in \Upsilon_i} x$$

$$\Upsilon_i = \{x \in I \mid \sum_{j \leq x} in_{ij} \geq wb_ratio_under \cdot total_i\}$$

$$q_over_i = \min_{x \in O_i} x$$

$$O_i = \{x \in I \mid \sum_{j \leq x} in_{ij} > wb_ratio_over \cdot total_i\} \cup \{whitepoint\}$$

$$range_i = q_over_i - q_under_i$$

$$cut_under_i = \frac{\lfloor q_under_i - range_i \cdot wb_margin_under \rfloor}{whitepoint}$$

$$cut_over_i = \frac{\lfloor q_over_i + range_i \cdot wb_margin_over \rfloor}{whitepoint}$$

$$out_off_i = \begin{cases} cut_under_i & cut_under_i \geq 0 \\ 0 & cut_under_i < 0 \end{cases}$$

$$out_gain_i = \begin{cases} \frac{comp_range}{cut_over_i - out_off_i} & cut_over_i \leq 1 \\ \frac{comp_range}{1 - out_off_i} & cut_over_i > 1 \end{cases}$$

exposure

For exposure calculation only channel with the highest current mean value is evaluated. Either median or mean value is taken (depending on chosen algorithm mode, which can be switched automatically by comparing how much these values differ) and compared to target value. Exposure correction factor is calculated from average of these two values and then applied to current exposure to get new exposure setting.

$$middle_i = \min_{x \in M_i} x \quad (b)$$

$$M_i = \{x \in I \mid \sum_{j \leq x} in_{ij} > \frac{total_i}{2}\} \quad (c)$$

$$median = \frac{middle_m}{whitepoint} \quad (d)$$

$$mean = \frac{sum_m}{total_m \cdot whitepoint} \quad (e)$$

$$target_mean = 2^{ev_correction-1} \quad (f)$$

$$target_median = 2^{hdr_median_ev} \quad (g)$$

$$hdr_diff = \begin{cases} hdr_threshold_high & \frac{mean - median}{mean} > hdr_diff \text{ for previous image} \\ hdr_threshold_low & \text{otherwise} \end{cases} \quad (h)$$

$$exp_corr = \begin{cases} \frac{mean + target_median}{2 \cdot mean} & \frac{mean - median}{mean} \leq hdr_diff \\ \frac{median + target_median}{2 \cdot median} & \frac{mean - median}{mean} > hdr_diff \end{cases} \quad (i)$$

$$gain_weight = \begin{cases} 1 & exp_corr < 1 \text{ and } \left| \frac{min_exposure - exposure}{exposure} \right| < exposure_margin \\ 1 & min_exposure \geq max_exposure \\ 1 & exp_corr > 1 \text{ and } \left| \frac{max_exposure - exposure}{exposure} \right| < exposure_margin \\ gain_priority & \text{otherwise} \end{cases} \quad (j)$$

where *exposure* is exposure time taken from image metadata

$$target_gain = gain + \left\lceil \frac{20 \cdot \log_{10}((exp_corr - 1) \cdot gain_weight + 1)}{gain_step} - \frac{1}{2} \right\rceil \cdot gain_step \quad (k)$$

where *gain* is gain value taken from image metadata

$$out_gain = \begin{cases} min_gain & target_gain \leq min_gain < max_gain \\ target_gain & min_gain < target_gain < max_gain \\ max_gain & min_gain < max_gain \leq target_gain \\ gain & min_gain \geq max_gain \end{cases} \quad (l)$$

$$target_exp = exposure \cdot exp_corr \cdot 10^{\frac{gain - out_gain}{20}} \quad (m)$$

$$set_exp = \begin{cases} min_exposure & target_exp \leq min_exposure < max_exposure \\ target_exp & min_exposure < target_exp < max_exposure \\ max_exposure & min_exposure < max_exposure \leq target_exp \\ exposure & min_exposure \geq max_exposure \end{cases} \quad (n)$$

$$out_exp = \begin{cases} set_exp & \frac{set_exp - exposure}{exposure} \leq -exposure_margin \\ exposure & -exposure_margin < \frac{set_exp - exposure}{exposure} < exposure_margin \\ set_exp & exposure_margin \leq \frac{set_exp - exposure}{exposure} \end{cases} \quad (o)$$

(b)-(c) defines non-normalized median value. (d)-(e) defines normalized mean and median values. (f)-(g) defines target mean and median values. (h)-(i) selects auto-exposure mode and applies it to get exposure correction factor. (j) boosts the ratio between gain and exposure time adjustments for exposure correction, if exposure time can't be changed further. (k) calculates target gain value. (l) clamps calculated gain value to the defined boundaries. (m) calculates target exposure time. (n) clamps calculated exposure time to the defined boundaries. (o) checks if target exposure time falls within specified margins from the current value and discards an update in that case.

parameters

- `cpu_device_id`: CPU device ID
- `aec_enabled` (default false): enable/disable exposure calculation and control, can be modified at runtime
- `awb_enabled` (default false): enable/disable white balance calculation and control, can be modified at runtime
- `noise_floor` (default 0.01): normalized noise floor (affects simple white balance calculation)
- `saturation` (default 0.987): if normalized pixel value is above this threshold it is considered saturated (affects simple white balance calculation)
- `min_area` (default 0.01): minimal non-saturated area (1.0 being whole image) required to trigger simple white balance calculation

- `wb_stretch` (default false): enables histogram stretch white balance algorithm instead of simple one
- `wb_ratio_under` (default 0.0): percentile for shadow compression section in histogram stretch white balance
- `wb_ratio_over` (default 1.0): percentile for highlights compression section in histogram stretch white balance
- `wb_margin_under` (default 0.0): relative margin for shadow compression section in histogram stretch white balance
- `wb_margin_over` (default 0.0): relative margin for highlights compression section in histogram stretch white balance
- `wb_comp_min` (default 0.0): maximum normalized value for shadow compression section in histogram stretch white balance
- `wb_comp_max` (default 1.0): minimum normalized value for highlights compression section in histogram stretch white balance
- `ctrl_latency` (default 3): how many frames to skip after adjusting the exposure before evaluating it again
- `add_frames` (default 0): allows to accumulate a histogram from several frames, useful in case of flickering image e.g. due to artificial lighting
- `min_exposure` (default 100): minimum exposure time in microseconds that is going to be set
- `max_exposure` (default 0): maximum exposure time in microseconds that is going to be set
- `min_gain` (default 0.0): minimum gain in dB that is going to be set
- `max_gain` (default 0.0): maximum gain in dB that is going to be set
- `gain_step` (default 1.0): granularity of camera gain control in dB
- `gain_priority` (default 0.5): prefer changing exposure time (lower values) or gain (higher values), valid range from 0.0 to 1.0
- `exposure_margin` (default 0.05): do not adjust the exposure if relative change is less than this value
- `hdr_threshold_low` (default 1.0 meaning HDR mode disabled): switch to LDR mode if median value is not bigger than mean value by that relative to mean value amount
- `hdr_threshold_high` (default 1.0 meaning HDR mode disabled): switch to HDR mode if median value is bigger than mean value by that relative to mean value amount
- `ev_correction` (default 0.0): correction in EV stops of target mean value compared to 50% (-1 EV) for LDR mode, can be modified at runtime
- `hdr_median_ev` (default -3.0): target median value in EV stops (0 EV is white point) for HDR mode

Use value 1.0 for `hdr_threshold_low` and `hdr_threshold_high` to disable HDR mode, and -65536.0 to disable LDR mode.

callbacks

- `wb_callback` - called when white balance parameters have been calculated by the element
wb_callback data format:

```

1 {
2     "wb": {
3         "r": 1.0,
4         "g1": 1.0,
5         "g2": 1.0,
6         "b": 1.0,
7         "r_off": 0.0,

```

```

8     "g1_off": 0.0,
9     "g2_off": 0.0,
10    "b_off": 0.0
11  }
12 }

```

- wb: calculated white balance parameters

- exposure_callback - called when exposure and gain parameters have been calculated by the element

exposure_callback data format:

```

1 {
2   "exposure": 10000,
3   "gain": 1.0
4 }

```

- exposure: calculated exposure time in microseconds

- gain: calculated gain in dB

4.2.2 files_writer

Writes all received frames to a given file in the given directory until stopped or end-of-stream event is received. Each time start command is received by writer it begins a new file.

JSON configuration:

```

1 {
2   "id": "writer",
3   "type": "files_writer",
4   "max_processing_count": 2,
5   "autostart": false,
6   "cpu_device_id": "cpu_dev",
7   "write_directory": "saved_files",
8   "direct_io": false,
9   "io_timer_interval": 10
10 }

```

parameters

- cpu_device_id: CPU device ID
- write_directory (default "saved_files"): path to the directory to save files in
- direct_io (default false): whether to use direct I/O (O_DIRECT on Linux, FILE_FLAG_NO_BUFFERING | FILE_FLAG_WRITE_THROUGH on Windows, F_NOCACHE on macOS)
- io_timer_interval (default 10): file I/O status update interval in milliseconds

commands

- on - takes the following parameters:
 - filename: name of the file to write, ISO 8601 time stamp is used by default (if this parameter is empty or omitted)

4.2.3 frame_exporter

Dispatches each received buffer to an external consumer via the assigned callback (see [iff_set_export_callback\(\)](#)). Dispatch is carried out from a separate thread. It should be used to pass frame data across IFF SDK library boundaries.

JSON configuration:

```

1 {
2     "id": "exporter",
3     "type": "frame_exporter",
4     "max_processing_count": 2,
5     "autostart": false,
6     "device_id": "cuda_dev"
7 }
```

parameters

- device_id: Device ID

4.2.4 frames_writer

Writes each received frame to a separate file in the given directory.

JSON configuration:

```

1 {
2     "id": "writer",
3     "type": "frames_writer",
4     "max_processing_count": 2,
5     "autostart": false,
6     "cpu_device_id": "cpu_dev",
7     "base_directory": "saved_frames",
8     "direct_io": true,
9     "filename_template": "{sequence_number:06}.raw",
10    "template_params": {
11        "aperture": 1.4
12    },
13    "io_timer_interval": 10
14 }
```

parameters

- cpu_device_id: CPU device ID
- base_directory (default "saved_frames"): path to the directory to save files in
- direct_io (default true): whether to use direct I/O (O_DIRECT on Linux, FILE_FLAG_NO_BUFFERING | FILE_FLAG_WRITE_THROUGH on Windows, F_NOCACHE on macOS)
- filename_template (default "{sequence_number:06}.raw"): string in **{fmt} library format** to use as filename template. Each {param_name} is a name of corresponding frame metadata field. Possible parameter names are:
 - sequence_number - frame sequence number for current recording session
 - padding - frame data padding
 - format - frame pixel format
 - width - frame width

- height - frame height
- offset_x - frame horizontal offset
- offset_y - frame vertical offset
- src_ts - frame timestamp (usually in micro-seconds) provided by camera or other source
- ntp_ts - frame NTP UTC date and time, use `strftime`-like formatting
- ntp_ts_local - frame NTP local date and time, use `strftime`-like formatting
- ntp_ts_us - sub-second part of frame NTP timestamp in micro-seconds
- utc_time - frame NTP UTC date and time in ISO 8601 format (same as `{ntp_ts:%Y%m%dT%H%M%S}.{ntp_ts_us:06}Z`)
- black_level - frame black level
- exposure - frame exposure time
- gain - frame gain
- sequence_id - frame sequence id
- template_params (optional): additional static parameters (string or number) for filename_template
- io_timer_interval (default 10): file I/O status update interval in milliseconds

special parameters

frames_writer has one additional read only parameter:

- data_offset: offset in bytes (metadata header size) where image data starts in recorded file

commands

- on - takes the following parameters:
 - subdirectory (default ""): directory to append to base_directory
 - frames_count (default 0): maximum number of frames to write, zero means no limit

callbacks

- frame_written_callback - called for every frame

frame_written_callback data format:

```
1 {
2   "success": true
3 }
```

- success: whether the frame was successfully written

- write_complete_callback - called when the element is turned off

write_complete_callback data format:

```
1 {
2   "written_frames_count": 42
3 }
```

- written_frames_count: number of written (successfully or not) frames since the last time the element was turned on

4.2.5 dng_writer

Writes each received image to a separate uncompressed DNG file in the given directory. Creates the following outputs for each of supported input formats:

- Mono and Monopmsb - LinearRaw DNG

- Bayer and Bayerpmsb - CFA DNG
- RGB - RGB TIFF
- BGR - RGB TIFF with switched blue and red channels
- RGBA - RGB TIFF with alpha channel (not well supported)
- BGRA - RGB TIFF with alpha channel and switched blue and red channels
- Monop - non-standard LinearRaw DNG with Compression set to 65042
- Bayerp - non-standard CFA DNG with Compression set to 65042

JSON configuration:

```

1 {
2     "id": "writer",
3     "type": "dng_writer",
4     "max_processing_count": 2,
5     "autostart": false,
6     "cpu_device_id": "cpu_dev",
7     "base_directory": "saved_frames",
8     "io_timer_interval": 10,
9     "filename_template": "{sequence_number:06}.raw",
10    "make": "",
11    "model": "",
12    "serial_number": "",
13    "copyright": "",
14    "description": "",
15    "base_iso": 0.0,
16    "baseline_exposure": 0.0,
17    "frame_rate": 0.0,
18    "base_frame_rate": "30,25,24",
19    "t_stop": 0.0,
20    "reel_name": "",
21    "camera_label": "",
22    "orientation": "normal",
23    "wb_preapplied": false,
24    "color_profile": {
25        "CalibrationIlluminant1": "D50",
26        "ColorMatrix1": [
27            3.1338561, -1.6168667, -0.4906146,
28            -0.9787684, 1.9161415, 0.0334540,
29            0.0719453, -0.2289914, 1.4052427
30        ]
31    },
32    "dcp_file": ""
33 }

```

parameters

All [frames_writer](#) parameters are supported with an addition of:

- `make` (default `""`): string, that will be written to Make TIFF tag and UniqueCameraModel DNG tag
- `model` (default `""`): string, that will be written to Model TIFF tag and UniqueCameraModel DNG tag
- `serial_number` (default `""`): string, that will be written to CameraSerialNumber DNG tag, if not empty

- `copyright` (default `""`): string, that will be written to Copyright TIFF tag
- `description` (default `""`): string, that will be written to ImageDescription TIFF tag
- `base_iso` (default 0.0): base ISO rating of the camera (with gain set to zero), that will be used to compute ISOSpeedRatings TIFF tag value, if not zero
- `baseline_exposure` (default 0.0): rational number, that will be written to BaselineExposure DNG tag, if not zero
- `frame_rate` (default 0.0): rational number, that will be written to FrameRate CinemaDNG tag, if not zero
- `base_frame_rate` (default `"30,25,24"`): one of the following strings, which specifies the order in which base (super) frame rates are checked to be a factor of `frame_rate` when creating a SMPTE time code for TimeCodes CinemaDNG tag:
 - `"24,25,30"`
 - `"24,30,25"`
 - `"25,24,30"`
 - `"25,30,24"`
 - `"30,24,25"`
 - `"30,25,24"` (default)
- `t_stop` (default 0.0): rational number, that will be written to TStop CinemaDNG tag, if not zero
- `reel_name` (default `""`): string, that will be written to ReelName CinemaDNG tag, if not empty
- `camera_label` (default `""`): string, that will be written to CameraLabel CinemaDNG tag, if not empty
- `orientation` (default `"normal"`): value, that will be written to Orientation TIFF tag, specified as an integer number or as one of the following strings:
 - `"top_left"` (1) - default
 - `"normal"` (1) - default
 - `"top_right"` (2)
 - `"mirrored_horiz"` (2)
 - `"bottom_right"` (3)
 - `"rotated_180"` (3)
 - `"bottom_left"` (4)
 - `"mirrored_vert"` (4)
 - `"left_top"` (5)
 - `"right_top"` (6)
 - `"rotated_cw_90"` (6)
 - `"right_bottom"` (7)
 - `"left_bottom"` (8)
 - `"rotated_ccw_90"` (8)
 - `"unknown"` (9)
- `wb_preapplied` (default false): whether white balance has been already applied to the incoming Bayer image (ColorMatrix and AsShotNeutral DNG tags are adjusted accordingly in this case)
- `color_profile` (optional): DNG color profile, that will be embedded into the file in case of Bayer image format, with the following supported DNG tags:
 - `CalibrationIlluminant1` (default `"D50"`): can be specified as an integer number or as one of the following strings:
 - * `"Unknown"` (0)
 - * `"Daylight"` (1)
 - * `"Fluorescent"` (2)
 - * `"Tungsten"` (3)

- * "Flash" (4)
- * "FineWeather" (9)
- * "Cloudy" (10)
- * "Shade" (11)
- * "DaylightFluorescent" (12)
- * "DayWhiteFluorescent" (13)
- * "CoolWhiteFluorescent" (14)
- * "WhiteFluorescent" (15)
- * "WarmWhiteFluorescent" (16)
- * "StandardLightA" (17)
- * "StandardLightB" (18)
- * "StandardLightC" (19)
- * "D55" (20)
- * "D65" (21)
- * "D75" (22)
- * "D50" (23) - default
- * "ISOStudioTungsten" (24)
- * "Other" (255)
- ColorMatrix1 (default **XYZ D50 to sRGB matrix**): 3x3 matrix of floats
- dcp_file (optional): path to DNG color profile file, with the following DNG tags used from it for the output files in case of Bayer image format:
 - BaselineExposureOffset - SRATIONAL tag type is written (and allowed in input) instead of stated in DNG specification RATIONAL type (which is also accepted in input), since value can be negative
 - CalibrationIlluminant1 - takes precedence over the one specified in color_profile parameter
 - CalibrationIlluminant2
 - ColorMatrix1 - takes precedence over the one specified in color_profile parameter
 - ColorMatrix2
 - DefaultBlackRender
 - ForwardMatrix1
 - ForwardMatrix2
 - ProfileCalibrationSignature
 - ProfileCopyright
 - ProfileEmbedPolicy
 - ProfileHueSatMapData1
 - ProfileHueSatMapData2
 - ProfileHueSatMapDims
 - ProfileHueSatMapEncoding
 - ProfileLookTableData
 - ProfileLookTableDims
 - ProfileLookTableEncoding
 - ProfileName
 - ProfileToneCurve
 - UniqueCameraModel - value is compared to UniqueCameraModel DNG tag generated from make and model parameters and a warning is issued in case of mismatch

Other metadata tags, like white balance (AsShotNeutral), are filled from image metadata.

commands

All [frames_writer](#) commands are supported.

callbacks

All `frames_writer` callbacks are supported.

references

- [TIFF 6.0 Specification](#)
- [TIFF/EP Specification](#)
- [DNG Specification \(version 1.5.0.0\)](#)
- [CinemaDNG Image Data Format Specification \(version 1.1.0.0\)](#)
- SMPTE ST 331:2011 "Element and Metadata Definitions for the SDTI-CP"
- SMPTE ST 12-1:2014 "Time and Control Code"
- SMPTE ST 309:2012 "Transmission of Date and Time Zone Information in Binary Groups of Time and Control Code"

4.2.6 exr_writer

Writes each received linear RGB image to a separate EXR file in the given directory.

JSON configuration:

```

1 {
2   "id": "writer",
3   "type": "exr_writer",
4   "max_processing_count": 2,
5   "autostart": false,
6   "cpu_device_id": "cpu_dev",
7   "base_directory": "saved_frames",
8   "filename_template": "{sequence_number:06}.exr",
9   "template_params": {
10    "aperture": 1.4
11  },
12  "data_format": "half",
13  "compression": "PIZ",
14  "zip_compression_level": 4,
15  "dwa_compression": 45.0,
16  "num_threads": 0,
17  "colorspace": "Rec709",
18  "temperature": 0.0,
19  "make": "",
20  "model": "",
21  "serial_number": "",
22  "copyright": "",
23  "description": "",
24  "base_iso": 0.0,
25  "baseline_exposure": 0.0,
26  "frame_rate": 0.0,
27  "base_frame_rate": "30,25,24",
28  "t_stop": 0.0,
29  "reel_name": "",
30  "camera_label": ""
31 }
```

parameters

- `cpu_device_id`: CPU device ID

- `base_directory` (default "saved_frames"): path to the directory to save files in
- `filename_template` (default "{sequence_number:06}.exr"): string in `{fmt} library format` to use as filename template. Each `{param_name}` is a name of corresponding frame metadata field. Possible parameter names are:
 - `sequence_number` - frame sequence number for current recording session
 - `padding` - frame data padding
 - `format` - frame pixel format
 - `width` - frame width
 - `height` - frame height
 - `offset_x` - frame horizontal offset
 - `offset_y` - frame vertical offset
 - `src_ts` - frame timestamp (usually in micro-seconds) provided by camera or other source
 - `ntp_ts` - frame NTP UTC date and time, use `strftime`-like formatting
 - `ntp_ts_local` - frame NTP local date and time, use `strftime`-like formatting
 - `ntp_ts_us` - sub-second part of frame NTP timestamp in micro-seconds
 - `utc_time` - frame NTP UTC date and time in ISO 8601 format (same as `{ntp_ts:%Y%m%dT%H%M%S}.{ntp_ts_us:06}Z`)
 - `black_level` - frame black level
 - `exposure` - frame exposure time
 - `gain` - frame gain
 - `sequence_id` - frame sequence id
- `template_params` (optional): additional static parameters (string or number) for `filename_template`
- `data_format` (default "half"): data storage format of written pixels, one of the following:
 - `half` (default) - 16-bit floating-point numbers
 - `float` - 32-bit floating-point numbers
- `compression` (default "PIZ"): compression algorithm, one of the following:
 - `NO` - no compression
 - `RLE` - run length encoding
 - `ZIPS` - zlib compression, one scan-line at a time
 - `ZIP` - zlib compression, in blocks of 16 scan-lines
 - `PIZ` (default) - PIZ-based wavelet compression
 - `PXR24` - lossy 24-bit float compression
 - `B44` - lossy 4-by-4 pixel block compression, fixed compression rate
 - `B44A` - lossy 4-by-4 pixel block compression, flat fields are compressed more
 - `DWAA` - lossy DCT-based compression, in blocks of 32 scan-lines, more efficient for partial buffer access
 - `DWAB` - lossy DCT-based compression, in blocks of 256 scan-lines, more efficient space-wise and faster to decode full frames than `DWAA`
- `zip_compression_level` (default 4): compression level setting used in `ZIPS`, `ZIP`, `DWAA` and `DWAB` algorithms, ranging from 0 to 9 (higher values result in smaller files)
- `dwa_compression_level` (default 45.0): compression level setting used in `DWAA` and `DWAB` algorithms, ranging from 0.0 to 100.0 (higher values result in smaller files)
- `num_threads` (default 0): number of worker threads, non-positive value means auto-detect (using `std::thread::hardware_concurrency()`)
- `colorspace` (default "Rec709"): color space name, used to fill chromaticities and adoptedNeutral attributes, one of the following:
 - `ACES`
 - `ACEScg`

- DisplayP3
- ProPhotoRGB
- Rec709 (default) - same as sRGB
- Rec2020
- temperature (default 0.0): number, that will be written to cameraCCTSetting attribute, if positive
- make (default ""): string, that will be written to cameraMake and cameraUuid attributes, if not empty
- model (default ""): string, that will be written to cameraModel and cameraUuid attributes, if not empty
- serial_number (default ""): string, that will be written to cameraSerialNumber and cameraUuid attributes, if not empty
- copyright (default ""): string, that will be written to owner attribute, if not empty
- description (default ""): string, that will be written to comments attribute, if not empty
- base_iso (default 0.0): base ISO rating of the camera (with gain set to zero), that will be used to compute isoSpeed attribute value, if positive
- baseline_exposure (default 0.0): exposure compensation setting in EV units, that will be used for scaling of output values (by default the output range is from 0.0 to 1.0)
- frame_rate (default 0.0): number, that will be written to captureRate and framesPerSecond attributes and will be used to calculate shutterAngle attribute value, if positive
- base_frame_rate (default "30,25,24"): one of the following strings, which specifies the order in which base (super) frame rates are checked to be a factor of frame_rate when creating a SMPTE time code for timeCode attribute:
 - "24,25,30"
 - "24,30,25"
 - "25,24,30"
 - "25,30,24"
 - "30,24,25"
 - "30,25,24" (default)
- t_stop (default 0.0): number, that will be written to tStop attribute, if positive
- reel_name (default ""): string, that will be written to reelName attribute, if not empty
- camera_label (default ""): string, that will be written to cameraLabel attribute, if not empty

Other metadata tags, like exposure time (expTime) and capture date (capDate), are filled from image metadata.

commands

All [frames_writer](#) commands are supported.

callbacks

All [frames_writer](#) callbacks are supported.

references

- [OpenEXR Standard Attributes](#)
- SMPTE ST 331:2011 "Element and Metadata Definitions for the SDTI-CP"
- SMPTE ST 12-1:2014 "Time and Control Code"
- SMPTE ST 309:2012 "Transmission of Date and Time Zone Information in Binary Groups of Time and Control Code"

4.2.7 metadata_saver

Saves metadata of received images to an internal buffer, which can be accessed externally.

JSON configuration:

```

1 {
2   "id": "metadata",
3   "type": "metadata_saver",
4   "max_processing_count": 2,
5   "autostart": false,
6   "cache_size": 4096
7 }
```

parameters

- `cache_size` (default 4096): maximum metadata buffer size in number of frames

Older information gets dropped when number of images for which metadata was saved exceeds `cache_size` limit.

special parameters

- `metadata` (read only): saved metadata can be read by getting the value of this parameter

metadata parameter data format:

```

1 {
2   "metadata": [
3     {
4       "frame": 0,
5       "sequence_id": 2,
6       "ntp_ts": 16832616755504369933,
7       "rtp_ts": 1374027318,
8       "unix_ts": 1710160193.562993,
9       "src_ts": 11,
10      "black_level": 0,
11      "exposure": 0,
12      "gain": 0.0,
13      "offset_x": 0,
14      "offset_y": 0,
15      "wb_b": 1.0,
16      "wb_b_off": 0.0,
17      "wb_g1": 1.0,
18      "wb_g1_off": 0.0,
19      "wb_g2": 1.0,
20      "wb_g2_off": 0.0,
21      "wb_r": 1.0,
22      "wb_r_off": 0.0
23    },
24    {
25      "frame": 1,
26      "sequence_id": 2,
27      "ntp_ts": 16832616755934335837,
28      "rtp_ts": 1374036328,
29      "unix_ts": 1710160193.6631024,
30      "src_ts": 12,
31      "black_level": 0,
32      "exposure": 0,
```

```

33         "gain": 0.0,
34         "offset_x": 0,
35         "offset_y": 0,
36         "wb_b": 1.0,
37         "wb_b_off": 0.0,
38         "wb_g1": 1.0,
39         "wb_g1_off": 0.0,
40         "wb_g2": 1.0,
41         "wb_g2_off": 0.0,
42         "wb_r": 1.0,
43         "wb_r_off": 0.0
44     }
45 ]
46 }

```

- frame: image sequence number
- sequence_id: ID of a dispatch session within which given image was dispatched, provided by source
- ntp_ts: image timestamp in NTP format (see [RFC 5905](#))
- rtp_ts: image timestamp as it is transmitted in RTP header
- unix_ts: image timestamp as time in seconds since UNIX epoch
- src_ts: image timestamp provided by source
- black_level: image black level
- exposure: image exposure time in microseconds
- gain: image gain in dB
- offset_x: horizontal offset of ROI or crop position
- offset_y: vertical offset of ROI or crop position
- image white balance coefficients:
 - * wb_b_off
 - * wb_g1
 - * wb_g1_off
 - * wb_g2
 - * wb_g2_off
 - * wb_r
 - * wb_r_off

4.2.8 rtsp_stream

Represents an RTSP video stream. Automates creation and configuration of RTSP resources within RTSP streaming server.

JSON configuration:

```

1 {
2     "id": "netstream",
3     "type": "rtsp_stream",
4     "relative_uri": "/cam",
5     "name": "netstream"
6 }

```

parameters

- relative_uri: relative URI of an RTSP resource within RTSP server

- name (optional): name of the stream, set directly to the **a=control:** attribute of resource SDP (if this parameter is not specified component id will be used as a name)

Note

Common `max_processing_count` and `autostart` parameters along with `on` and `off` commands are ignored by `rtsp_stream` component. Image processing is instead automatically controlled by RTSP server itself based on RTSP client requests.

4.3 Filters

Filters are components that have inputs and outputs. They can be neither initial nor terminal link of the processing chain. Filters can analyze, alter or pass through as is their input frames stream.

4.3.1 averager

Averages specified number of input images.

JSON configuration:

```

1 {
2   "id": "avg",
3   "type": "averager",
4   "max_processing_count": 2,
5   "cpu_device_id": "cpu_dev",
6   "num_frames": 1
7 }
```

formula

$$out = \frac{1}{num_frames} \cdot \sum_i in_i$$

$$i \in \{1, 2, \dots, num_frames\}$$

parameters

- `cpu_device_id`: CPU device ID
- `num_frames` (default 1): number of images to average

Filter outputs one image per `num_frames` input images taking metadata from the first frame in sequence.

4.3.2 decoder

Decodes incoming video stream.

JSON configuration:

```

1 {
2   "id": "nvdec",
3   "type": "decoder",
4   "max_processing_count": 2,
5   "decoder_type": "nvidia",
6   "cpu_device_id": "cpu_dev",
7   "gpu_device_id": "cuda_dev"
8 }
```

parameters

- `decoder_type`: type of decoder library, must be `nvidia` (only NVIDIA hardware decoder is supported by IFF now)
- `cpu_device_id`: CPU device ID
- `gpu_device_id`: GPU device ID

4.3.3 encoder

Encodes NV12 (desktop GPU), YV12 (Jetson), P010 (desktop GPU and Jetson), Mono8 (Jetson) and Mono16 (Jetson) images to compressed H264 or H265 format.

JSON configuration:

```

1 {
2   "id": "nvenc",
3   "type": "encoder",
4   "max_processing_count": 2,
5   "encoder_type": "nvidia",
6   "cpu_device_id": "cpu_dev",
7   "gpu_device_id": "cuda_dev",
8   "codec": "H264",
9   "profile": "H264_HIGH",
10  "level": "H264_51",
11  "config_preset": "DEFAULT",
12  "preset_tuning": "ULTRA_LOW_LATENCY",
13  "multipass": "DISABLED",
14  "rc_mode": "CBR",
15  "fps": 30.0,
16  "bitrate": 300000000,
17  "max_bitrate": 400000000,
18  "idr_interval": 30,
19  "iframe_interval": 30,
20  "repeat_spspps": true,
21  "virtual_buffer_size": 0,
22  "slice_intrarefresh_interval": 0,
23  "qp": 28,
24  "min_qp_i": -1,
25  "max_qp_i": -1,
26  "min_qp_p": -1,
27  "max_qp_p": -1,
28  "report_metadata": false,
29  "max_performance": false
30 }
```

parameters

- `encoder_type`: type of encoder library, one of the following values:
 - `nvidia` - only NVIDIA hardware encoder is supported by IFF at the moment
- `cpu_device_id`: CPU device ID
- `gpu_device_id`: GPU device ID
- `codec`: video codec to use, one of the following values:
 - H264
 - H265

- profile (default "H264_HIGH", or "H265_MAIN", or "H265_MAIN10"): codec profile, one of the following values:
 - for H264 codec:
 - * H264_MAIN
 - * H264_BASELINE
 - * H264_HIGH (default)
 - for H265 codec:
 - * H265_MAIN (default for 8-bit input)
 - * H265_MAIN10 (default for 10-bit input)
- level (default "H264_51" or "H265_62_HIGH_TIER"): codec level, one of the following values:
 - for H264 codec:
 - * H264_1
 - * H264_1b
 - * H264_11
 - * H264_12
 - * H264_13
 - * H264_2
 - * H264_21
 - * H264_22
 - * H264_3
 - * H264_31
 - * H264_32
 - * H264_4
 - * H264_41
 - * H264_42
 - * H264_5
 - * H264_51 (default)
 - * H264_52
 - * H264_60
 - * H264_61
 - * H264_62
 - for H265 codec:
 - * H265_1_MAIN_TIER
 - * H265_2_MAIN_TIER
 - * H265_21_MAIN_TIER
 - * H265_3_MAIN_TIER
 - * H265_31_MAIN_TIER
 - * H265_4_MAIN_TIER
 - * H265_41_MAIN_TIER
 - * H265_5_MAIN_TIER
 - * H265_51_MAIN_TIER
 - * H265_52_MAIN_TIER
 - * H265_6_MAIN_TIER
 - * H265_61_MAIN_TIER
 - * H265_62_MAIN_TIER
 - * H265_1_HIGH_TIER
 - * H265_2_HIGH_TIER
 - * H265_21_HIGH_TIER
 - * H265_3_HIGH_TIER

- * H265_31_HIGH_TIER
- * H265_4_HIGH_TIER
- * H265_41_HIGH_TIER
- * H265_5_HIGH_TIER
- * H265_51_HIGH_TIER
- * H265_52_HIGH_TIER
- * H265_6_HIGH_TIER
- * H265_61_HIGH_TIER
- * H265_62_HIGH_TIER (default)
- config_preset (default "DEFAULT"): encoding preset, one of the following presets:
 - on Jetson:
 - * TEGRA_DISABLE - "Disabled" encoder hardware preset
 - * TEGRA_ULTRAFAST or DEFAULT - encoder hardware preset with "Ultra-Fast" per frame encode time
 - * TEGRA_FAST - encoder hardware preset with "Fast" per frame encode time
 - * TEGRA_MEDIUM - encoder hardware preset with "Medium" per frame encode time
 - * TEGRA_SLOW - encoder hardware preset with "Slow" per frame encode time
 - on desktop GPU (performance degrades and quality improves as we move from P1 to P7):
 - * P1 or DEFAULT
 - * P2
 - * P3
 - * P4
 - * P5
 - * P6
 - * P7
- preset_tuning (default "ULTRA_LOW_LATENCY"): preset tuning mode supported on desktop GPU only, one of the following modes:
 - LOSSLESS - tune presets for lossless encoding
 - HIGH_QUALITY - tune presets for latency tolerant encoding
 - LOW_LATENCY - tune presets for low latency streaming
 - ULTRA_LOW_LATENCY (default) - tune presets for ultra low latency streaming
- multipass (default "DISABLED"): multi pass encoding mode. Supported on desktop GPU only. Following modes are supported:
 - DISABLED (default) - single pass mode
 - QUARTER_RESOLUTION - two pass encoding is enabled where first pass is quarter resolution
 - FULL_RESOLUTION - two pass encoding is enabled where first pass is full resolution
- rc_mode (default "CBR"): rate control mode, one of the following:
 - on both Jetson and desktop GPU:
 - * VBR - variable bit-rate mode
 - * CBR (default) - constant bit-rate mode
 - on desktop GPU only:
 - * CONSTQP - constant QP mode
- fps(default 30.0): encoder fps, can be modified at runtime
- bitrate (default 4194304): stream bit-rate in bps, can be modified at runtime
- max_bitrate (optional): maximum stream bit-rate, used for VBR mode only
- idr_interval (default 30): IDR frame interval
- iframe_interval (default 30): I frame interval

- `repeat_spspps` (default `true`): whether to attach SPS/PPS/VPS to each IDR frame, otherwise they are attached only to the first one
- `virtual_buffer_size` (default 0): specifies the VBV/HRD buffer size in bits, set 0 to use the default buffer size
- `slice_intrarefresh_interval` (default 0): specify the encoder slice intra refresh interval
- `qp` (default 28): specifies QP to be used for encoding
- `min_qp_i`: min QP for I-frames
- `max_qp_i`: max QP for I-frames
- `min_qp_p`: min QP for P-frames
- `max_qp_p`: max QP for P-frames
- `report_metadata` (default `false`): if set to `true` encoder will output metadata with every encoded frame
- `max_performance` (default `false`): for Jetson only, set to `true` to enable maximum performance

commands

- `force_idr` - forces next incoming image to be encoded as an IDR frame, takes no parameters

4.3.4 fps_limiter

Drops frames which come faster than specified frame rate.

JSON configuration:

```

1 {
2     "id": "fps_limit",
3     "type": "fps_limiter",
4     "max_processing_count": 2,
5     "framerate": 0.0,
6     "jitter": 0.05
7 }
```

parameters

- `framerate` (default 0.0): maximum output frame rate, zero or negative value means unlimited
- `jitter` (default 0.05): allowed jitter expressed in units of one period (reciprocal of `framerate`), valid range from zero to one (inclusive)

4.3.5 frame_dropper

Drops frames in the repeating pattern: pass N frames, drop M frames.

JSON configuration:

```

1 {
2     "id": "drop",
3     "type": "frame_dropper",
4     "max_processing_count": 2,
5     "dispatch_count": 1,
6     "drop_count": 1
7 }
```

parameters

- `dispatch_count` (default 1): how many frames to pass-through at the beginning of the pattern
- `drop_count` (default 1): how many frames to drop at the end of the pattern

$\text{dispatch_count} / (\text{dispatch_count} + \text{drop_count})$ gives the percentage of passed-through frames and consequently the FPS change factor.

4.3.6 gamma

Applies gamma curve using LUT to Mono or RGB input images while optionally changing image bit-depth.

JSON configuration:

```

1 {
2   "id": "oetf",
3   "type": "gamma",
4   "max_processing_count": 2,
5   "cpu_device_id": "cpu_dev",
6   "bitdepth": 0,
7   "linear": 0.0,
8   "power": 1.0
9 }
```

formula

$$\text{out} = (2^{\text{bitdepth}} - 1) \cdot \Gamma\left(\frac{\text{in}}{\text{white_level}}\right)$$

BT.709-like gamma

$$\Gamma(x) = \begin{cases} c \cdot x & x < \text{linear} \\ a \cdot x^{\text{power}} - b & x \geq \text{linear} \end{cases}$$

where a , b and c are calculated, so that $\Gamma(x)$ is smooth and passes through (0, 0) and (1, 1)

parameters

- `cpu_device_id`: CPU device ID
- `bitdepth` (default 0): output bit-depth, non-positive value (e.g. default zero) keeps input bit-depth for output
- `power` (default 1.0)
- `linear` (default 0.0)

Last 2 parameters define values of corresponding variables in BT.709-like gamma formula.

references

- [Recommendation ITU-R BT.709-6 \(06/2015\) "Parameter values for the HDTV standards for production and international programme exchange"](#)

4.3.7 highlight_recovery

Interpolates values of saturated pixels using highlight reconstruction algorithm based on ratios between Bayer channels. Input images must be in Bayer (unpacked) format.

JSON configuration:

```
1 {
2   "id": "highlights",
3   "type": "highlight_recovery",
4   "max_processing_count": 2,
5   "cpu_device_id": "cpu_dev",
6   "headroom_bits": 0,
7   "number_of_interpolation_threads": 0,
8   "interpolation_step": 2,
9   "denoise": true,
10  "rolloff": 4.0,
11  "dark_rolloff": 16.0,
12  "dark": 0.125,
13  "threshold": 0.987
14 }
```

parameters

- `cpu_device_id`: CPU device ID
- `headroom_bits` (default 0): image bit-depth will be increased by this number, zero value disables processing, negative value fixes output bit-depth at 16
- `number_of_interpolation_threads` (default 0): number of processing threads, non-positive value means auto-detect (using `std::thread::hardware_concurrency()`)
- `interpolation_step` (default 2): possible values are:
 - 1 - interpolate each pixel 8 times, which may produce better results at the cost of the processing speed
 - 2 (default) - interpolate each pixel 4 times, which is faster and usually visually indistinguishable
- `denoise` (default true): whether to apply simple denoising algorithm (5x5 median filter) to the reconstructed highlights
- `rolloff` (default 4.0): force of smoothing applied to channel ratio changing over vertical and horizontal directions, use higher values to deal with fringes (e.g. due to aberrations)
- `dark_rolloff` (default 16.0): same as `rolloff`, but for dark pixels, scale together with `rolloff`
- `dark` (default 0.125): if normalized pixel value after white balance is below this value it is considered too dark and so white color is used for channel ratio calculation instead, decrease for darker scenes
- `threshold` (default 0.987): if normalized pixel value is above this value it is considered saturated and so reconstruction algorithm is applied to it

It is advised to set `baseline_exposure` parameter of `dng_writer` to the same value as `headroom_bits`.

4.3.8 histogram

Builds a histogram for Bayer or mono image (depth 8 to 16).

JSON configuration:

```
1 {
2   "id": "hist",
3   "type": "histogram",
4   "max_processing_count": 2,
5   "cpu_device_id": "cpu_dev",
6   "bins": 256
7 }
```

formula

$$whitepoint = bins - 1$$

$$out_{xy} = \sum_{(i,j) \in \Pi_y} I_x(in_{ij})$$

$$x \in \{0, 1, 2, \dots, whitepoint\}$$

$$y \in X$$

$$I_x(z) = \begin{cases} 0 & \frac{z}{white_level} < \frac{x}{whitepoint} \\ 1 & \frac{x}{whitepoint} \leq \frac{z}{white_level} < \frac{x+1}{whitepoint} \\ 0 & \frac{x+1}{whitepoint} \leq \frac{z}{white_level} \end{cases} \quad (a)$$

$$\Pi_y = \{(i, j) \mid i, j \in \mathbb{N}_0, i < w, j < h, (i + c_x) \bmod 2 + 2 \cdot ((j + c_y) \bmod 2) \in \Upsilon_y\} \quad (b)$$

where (w, h) are image dimensions,

and (c_x, c_y) defines image Bayer pattern shift compared to RGGB

$$\Upsilon_V = \{0, 1, 2, 3\}, \Upsilon_R = \{0\}, \Upsilon_G = \{1, 2\}, \Upsilon_B = \{3\}$$

(a) defines whether value z falls into bin x . (b) defines pixel positions for specific color channel from X .

parameters

- `cpu_device_id`: CPU device ID
- `bins` (default 256): bin count for histogram (should be a power of 2, from 256 to 65536)

Output format is one of the following:

- `HistogramMono<bins>Int` (Mono input image format) - $X = \{V\}$
- `Histogram3Bayer<bins>Int` (Bayer input image format) - $X = \{R, G, B\}$

All formats are stored in the memory as an array of 32-bit integers.

4.3.9 image_crop

Crops the image.

JSON configuration:

```

1 {
2   "id": "crop",
3   "type": "image_crop",
4   "max_processing_count": 2,
5   "cpu_device_id": "cpu_dev",
6   "offset_x": 0,
7   "offset_y": 0,
8   "width": 0,
9   "height": 0
10 }
```

parameters

- `cpu_device_id`: CPU device ID
- `offset_x`, `offset_y` (default 0): coordinates of top left corner of crop area, input image width/height is added to the value if it is negative
- `width`, `height` (default 0): dimensions of crop area, input image width/height is added to the value if it is non-positive

By default this filter just copies input image to output buffer, which could be used to get rid of a row padding.

4.3.10 metadata_exporter

Exports metadata of every frame passed through it using `new_frame_metadata` callback

JSON configuration:

```
1 {
2   "id": "metadata",
3   "type": "metadata_exporter",
4   "static_metadata": {
5     "ip": "127.0.0.1"
6   }
7 }
```

parameters

- `static_metadata`: any static metadata defined by user, this metadata will be added to the metadata of each frame

callbacks

- `new_frame_metadata` - called when the frame passes through the filter

`new_frame_metadata` data format:

```
1 {
2   "sequence_id": 1,
3   "sequence_ts": 16832616755504369933,
4   "sequence_num": 0,
5   "ntp_ts": 16832616755934335837,
6   "src_ts": 13738592,
7   "width": 3840,
8   "height": 2160,
9   "offset_x": 0,
10  "offset_y": 0,
11  "black_level": 0,
12  "exposure": 10000,
13  "gain": 0.0,
14  "wb_r": 1.0,
15  "wb_g1": 1.0,
16  "wb_g2": 1.0,
17  "wb_b": 1.0,
18  "wb_b_off": 0.0,
19  "wb_g1_off": 0.0,
20  "wb_g2_off": 0.0,
21  "wb_r_off": 0.0,
22  "static_metadata": {
23    "ip": "127.0.0.1"
24  }
25 }
```

- `sequence_id`: ID of a dispatch session within which given image was dispatched, provided by source
- `sequence_ts`: timestamp in NTP format (see [RFC 5905](#)) when current dispatch session was started
- `sequence_num`: image sequence number
- `ntp_ts`: image timestamp in NTP format (see [RFC 5905](#))
- `src_ts`: image timestamp provided by source

- width: image width
- height: image height
- offset_x: horizontal offset of ROI or crop position
- offset_y: vertical offset of ROI or crop position
- black_level: image black level
- exposure: image exposure time in microseconds
- gain: image gain in dB
- image white balance coefficients:
 - * wb_b_off
 - * wb_g1
 - * wb_g1_off
 - * wb_g2
 - * wb_g2_off
 - * wb_r
 - * wb_r_off
- static_metadata: static data identical for each frame, defined in the element configuration

4.3.11 packer

Converts unpacked Mono and Bayer image formats into packed Monopmsb and Bayerpmsb formats compatible with DNG specification. Input images that can't be packed (e.g. with RGB format) are passed through as is.

JSON configuration:

```
1 {
2   "id": "pack",
3   "type": "packer",
4   "max_processing_count": 2,
5   "cpu_device_id": "cpu_dev"
6 }
```

parameters

- cpu_device_id: CPU device ID

references

- [GenICam Pixel Format Naming Convention \(PFNC\) Version 2.4](#)
- [TIFF 6.0 Specification](#)
- [DNG Specification \(version 1.5.0.0\)](#)

4.3.12 resizer

Resizes the image.

JSON configuration:

```
1 {
2   "id": "resizer",
3   "type": "resizer",
4   "max_processing_count": 2,
5   "cpu_device_id": "cpu_dev",
6   "scale": 0.0,
```

```

7   "width": 1024,
8   "height": 1024
9 }

```

parameters

- `cpu_device_id`: CPU device ID
- `scale` (default 0.0): scale factor
- `width`, `height` (optional, if `scale` is positive): dimensions of the output resized image, used if `scale` is not positive

4.3.13 sub_monitor

Passes through any incoming images while providing callbacks on pipeline status change events.

JSON configuration:

```

1 {
2   "id": "sub_mon",
3   "type": "sub_monitor"
4 }

```

callbacks

- `on_new_consumer` - called when some connection to output of this element becomes active (images begin to flow), returns empty JSON object
- `on_active_changed` - called when this element starts or stops receiving images

on_active_changed data format:

```

1 {
2   "active": true
3 }

```

- `active`: whether element is currently active (is receiving images)

4.3.14 xiprocessor

Processes images using [xiAPI offline processing](#).

JSON configuration:

```

1 {
2   "id": "xiproc",
3   "type": "xiprocessor",
4   "max_processing_count": 2,
5   "cpu_device_id": "cpu_dev",
6   "custom_params": [
7     { "gammaY": 0.47 }
8   ],
9   "image_format": "RGB32",
10  "color": {
11    "dcp_file": "color_profile.dcp",
12    "temperature": 5003,
13    "output_colorspace": "Custom",
14    "xyz2rgb": [

```

```

15         3.1338561, -1.6168667, -0.4906146,
16         -0.9787684,  1.9161415,  0.0334540,
17         0.0719453, -0.2289914,  1.4052427
18     ]
19 },
20 "switch_red_and_blue": false,
21 "proc_num_threads": 0
22 }

```

parameters

- `cpu_device_id`: CPU device ID
- `custom_params` (optional): array of custom [parameters from xiAPI](#)
- `image_format` (default "RGB32"): output [xiAPI image data format](#), one of the following:
 - MON08
 - MON016
 - RAW8
 - RAW16
 - RGB24
 - RGB32 (default)
 - RGB48
 - RGB64
- `color` (optional):
 - `dcp_file` (required, if color section is present): path to DNG color profile file (only color matrices are used from it, ForwardMatrix1 tag is required to be present)
 - `temperature` (default 5003): white balance temperature, used for color matrix interpolation in case of dual-illuminant color profiles
 - `output_colorspace` (default "Custom"): output color space, used for color matrix calculation (gamma is not affected), one of the following:
 - * Custom (default) - custom color space as specified by `xyz2rgb` setting (see below)
 - * ACES
 - * ACEScg
 - * DisplayP3
 - * ProPhotoRGB
 - * Rec709 - same as sRGB
 - * Rec2020
 - `xyz2rgb` (default [XYZ D50 to sRGB matrix](#)): 3x3 XYZ D50 to RGB matrix of floats, which defines Custom output color space
- `switch_red_and_blue` (default false): whether to switch to RGB output channel order instead of xiAPI default BGR, will automatically adjust color matrix settings as required
- `proc_num_threads` (default 0): number of threads per image processor (if value is zero or negative auto-detected default is used)

Set `image_format` to RAW16 for just unpacking of packed transport data format or use default RGB32 setting for full processing including demosaicing.

4.3.15 cuda_processor

Processes incoming images on NVIDIA GPU. This filter can perform different processing operations on image. Those operations can be arranged into a pipeline.

JSON configuration:

```

1 {
2   "id": "gpuproc",
3   "type": "cuda_processor",
4   "max_processing_count": 2,
5   "cpu_device_id": "cpu_dev",
6   "gpu_device_id": "cuda_dev",
7   "color": {
8     "dcp_file": "color_profile.dcp",
9     "temperature": 5003,
10    "xyz2rgb": [
11      3.1338561, -1.6168667, -0.4906146,
12      -0.9787684, 1.9161415, 0.0334540,
13      0.0719453, -0.2289914, 1.4052427
14    ]
15  },
16  "elements": [
17    { "id": "import_from_host", "type": "import_from_host" },
18    { "id": "black_level", "type": "black_level" },
19    { "id": "white_balance", "type": "white_balance" },
20    { "id": "demosaic", "type": "demosaic", "algorithm": "HQLI ←
21      " },
22    { "id": "color_correction", "type": "color_correction" },
23    { "id": "gamma", "type": "gamma8", "linear": 0.018, " ←
24      power": 0.45 },
25    { "id": "export_to_device", "type": "export_to_device", "output_format": " ←
26      NV12_BT709", "output_name": "yuv" },
27    { "id": "hist", "type": "histogram", "output_format": " ←
28      Histogram4Bayer256Int", "output_name": "histogram" }
29  ],
30  "connections": [
31    { "src": "import_from_host", "dst": "black_level" },
32    { "src": "black_level", "dst": "white_balance" },
33    { "src": "white_balance", "dst": "demosaic" },
34    { "src": "demosaic", "dst": "color_correction" },
35    { "src": "color_correction", "dst": "gamma" },
36    { "src": "gamma", "dst": "export_to_device" },
37    { "src": "black_level", "dst": "hist" }
38  ]
39 }

```

parameters

- `cpu_device_id`: CPU device ID
- `gpu_device_id`: CUDA device ID
- `color` (optional):
 - `dcp_file` (required, if `color` section is present): path to DNG color profile file (only color matrices are used from it, `ForwardMatrix1` tag is required to be present)
 - `temperature` (default 5003): white balance temperature, used for color matrix interpolation in case of dual-illuminant color profiles
 - `xyz2rgb` (default **XYZ D50 to sRGB matrix**): 3x3 XYZ D50 to RGB matrix of floats, which defines Custom output color space
- `elements`: list of required `cuda_processor` pipeline elements (see section below)
 - `id`: unique element ID
 - `type`: element type (see section below for possible values)

- connections: list of edges which connect elements into pipeline
 - src: element ID used as a source of the connection
 - dst: element ID used as a destination of the connection

Import adapters

Exactly one import adapter must exist in the `cuda_processor` pipeline and it must be the first element (must be used in connections section at least once as `src` and never as `dst`).

`import_from_device`

Copies data from CUDA device buffer taking row pitch into account and unpacking in case of Mono12p and BayerXX12p formats.

JSON configuration:

```
1 {
2   "id": "import_from_device",
3   "type": "import_from_device"
4 }
```

`import_from_host`

Copies data from CPU buffer taking row pitch into account and unpacking in case of Mono12p and BayerXX12p formats. It's faster if buffer is CUDA-allocated (page-locked).

JSON configuration

```
1 {
2   "id": "import_from_host",
3   "type": "import_from_host"
4 }
```

Export adapters

Export adapters must be the last elements in the `cuda_processor` pipeline (each adapter must be used in connections section exactly once as `dst` and never as `src`).

Common required parameter for export adapters is:

```
1 {
2   "output_name": "out"
3 }
```

- `output_name`: name of the `cuda_processor` element output for this export adapter (use "out" for default output)

export_to_device

Copies data to CUDA device buffer, optionally converting to specified format.

JSON configuration:

```

1 {
2   "id": "export_to_device",
3   "type": "export_to_device",
4   "output_name": "out",
5   "output_format": "YV12_BT709"
6 }
```

formula for YUV conversion

$$Y' = K_R \cdot R' + (1 - K_R - K_B) \cdot G' + K_B \cdot B'$$

$$P'_B = \frac{1}{2} \cdot \frac{B' - Y'}{1 - K_B}$$

$$P'_R = \frac{1}{2} \cdot \frac{R' - Y'}{1 - K_R}$$

where R', G', B' are normalized to [0, 1]

for n -bit full range:

$$Y = 255 \cdot Y' \cdot 2^{n-8}$$

$$C_B = (255 \cdot P'_B + 128) \cdot 2^{n-8}$$

$$C_R = (255 \cdot P'_R + 128) \cdot 2^{n-8}$$

or in matrix form

$$\begin{pmatrix} Y \\ C_B \\ C_R \end{pmatrix} = \begin{pmatrix} K_R & 1 - K_R - K_B & K_B \\ \frac{1}{2} \cdot \frac{K_R}{K_B - 1} & \frac{1}{2} \cdot \frac{1 - K_R - K_B}{K_B - 1} & \frac{1}{2} \\ \frac{1}{2} \cdot \frac{K_R}{K_R - 1} & \frac{1}{2} \cdot \frac{1 - K_R - K_B}{K_R - 1} & \frac{1}{2} \cdot \frac{K_B}{K_R - 1} \end{pmatrix} \cdot \begin{pmatrix} 255 \cdot R' \\ 255 \cdot G' \\ 255 \cdot B' \end{pmatrix} + \begin{pmatrix} 0 \\ 128 \\ 128 \end{pmatrix} \cdot 2^{n-8}$$

for n -bit limited range:

$$Y = (219 \cdot Y' + 16) \cdot 2^{n-8}$$

$$C_B = (224 \cdot P'_B + 128) \cdot 2^{n-8}$$

$$C_R = (224 \cdot P'_R + 128) \cdot 2^{n-8}$$

or in matrix form

$$\begin{pmatrix} Y \\ C_B \\ C_R \end{pmatrix} = \begin{pmatrix} \frac{219}{255} \cdot K_R & \frac{219}{255} \cdot (1 - K_R - K_B) & \frac{219}{255} \cdot K_B \\ \frac{224}{255} \cdot \frac{1}{2} \cdot \frac{K_R}{K_B - 1} & \frac{224}{255} \cdot \frac{1}{2} \cdot \frac{1 - K_R - K_B}{K_B - 1} & \frac{224}{255} \cdot \frac{1}{2} \cdot \frac{K_B}{K_R - 1} \\ \frac{224}{255} \cdot \frac{1}{2} & \frac{224}{255} \cdot \frac{1}{2} \cdot \frac{1 - K_R - K_B}{K_R - 1} & \frac{224}{255} \cdot \frac{1}{2} \cdot \frac{K_B}{K_R - 1} \end{pmatrix} \cdot \begin{pmatrix} 255 \cdot R' \\ 255 \cdot G' \\ 255 \cdot B' \end{pmatrix} + \begin{pmatrix} 16 \\ 128 \\ 128 \end{pmatrix} \cdot 2^{n-8}$$

BT.601

$$K_R = 0.299$$

$$K_B = 0.114$$

for n -bit full range

$$\begin{pmatrix} Y \\ C_B \\ C_R \end{pmatrix} = \begin{pmatrix} 0.299 & 0.587 & 0.114 \\ -0.169 & -0.331 & 0.500 \\ 0.500 & -0.419 & -0.081 \end{pmatrix} \cdot \begin{pmatrix} 255 \cdot R' \\ 255 \cdot G' \\ 255 \cdot B' \end{pmatrix} + \begin{pmatrix} 0 \\ 128 \\ 128 \end{pmatrix} \cdot 2^{n-8}$$

for n -bit limited range

$$\begin{pmatrix} Y \\ C_B \\ C_R \end{pmatrix} = \left(\begin{pmatrix} 0.257 & 0.504 & 0.098 \\ -0.148 & -0.291 & 0.439 \\ 0.439 & -0.368 & -0.071 \end{pmatrix} \cdot \begin{pmatrix} 255 \cdot R' \\ 255 \cdot G' \\ 255 \cdot B' \end{pmatrix} + \begin{pmatrix} 16 \\ 128 \\ 128 \end{pmatrix} \right) \cdot 2^{n-8}$$

BT.709

$$K_R = 0.2126$$

$$K_B = 0.0722$$

for n -bit full range

$$\begin{pmatrix} Y \\ C_B \\ C_R \end{pmatrix} = \left(\begin{pmatrix} 0.2126 & 0.7152 & 0.0722 \\ -0.1146 & -0.3854 & 0.5000 \\ 0.5000 & -0.4542 & -0.0458 \end{pmatrix} \cdot \begin{pmatrix} 255 \cdot R' \\ 255 \cdot G' \\ 255 \cdot B' \end{pmatrix} + \begin{pmatrix} 0 \\ 128 \\ 128 \end{pmatrix} \right) \cdot 2^{n-8}$$

for n -bit limited range

$$\begin{pmatrix} Y \\ C_B \\ C_R \end{pmatrix} = \left(\begin{pmatrix} 0.1826 & 0.6142 & 0.0620 \\ -0.1007 & -0.3385 & 0.4392 \\ 0.4392 & -0.3990 & -0.0402 \end{pmatrix} \cdot \begin{pmatrix} 255 \cdot R' \\ 255 \cdot G' \\ 255 \cdot B' \end{pmatrix} + \begin{pmatrix} 16 \\ 128 \\ 128 \end{pmatrix} \right) \cdot 2^{n-8}$$

4:2:0 chroma subsampling

$$U_{xy} = \sum_{i=2 \cdot x}^{2 \cdot x+1} \sum_{j=2 \cdot y}^{2 \cdot y+1} \frac{C_{Bij}}{4}$$

$$V_{xy} = \sum_{i=2 \cdot x}^{2 \cdot x+1} \sum_{j=2 \cdot y}^{2 \cdot y+1} \frac{C_{Rij}}{4}$$

YUV formats

one cell represents one byte

(w, h) are image dimensions

$$\text{MSB}(z) = \left\lfloor \frac{z}{2^8} \right\rfloor \quad (\text{most significant byte})$$

$$\text{LSB}(z) = \left\{ \frac{z}{2^8} \right\} \cdot 2^8 \quad (\text{least significant byte})$$

YV12 (8-bit planar 4:2:0)

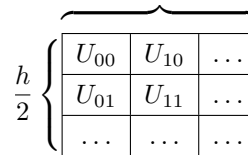
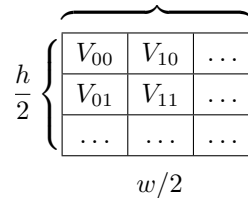
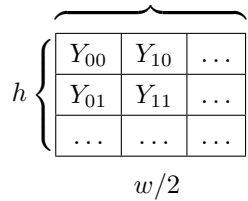

I420_10LE (10-bit planar 4:2:0)

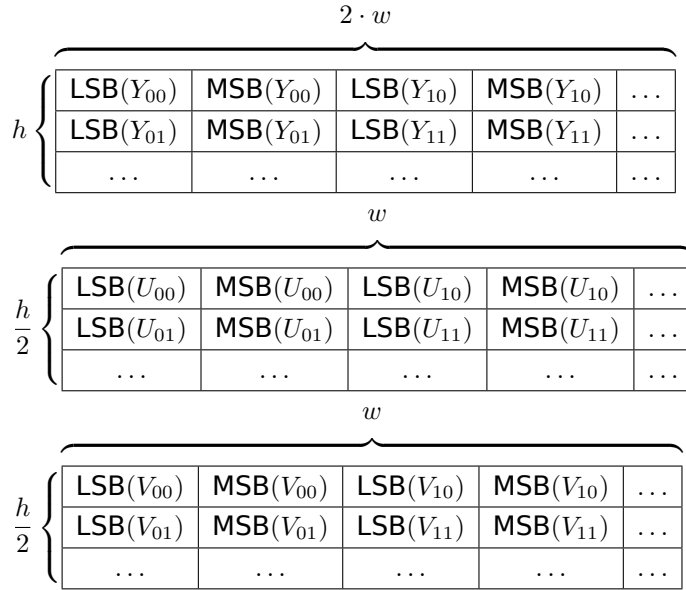

NV12 (8-bit semi-planar 4:2:0)

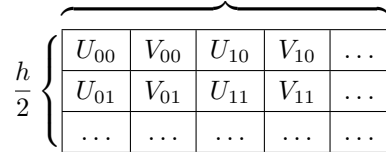
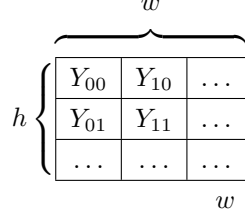

P010 (10-bit semi-planar 4:2:0)

$$\begin{pmatrix} \hat{Y} \\ \hat{U} \\ \hat{V} \end{pmatrix} = \begin{pmatrix} Y \\ U \\ V \end{pmatrix} \cdot 2^6$$

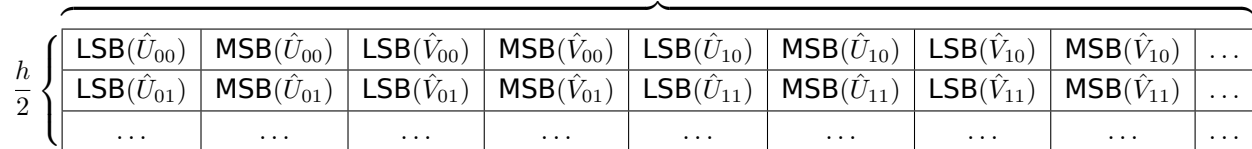
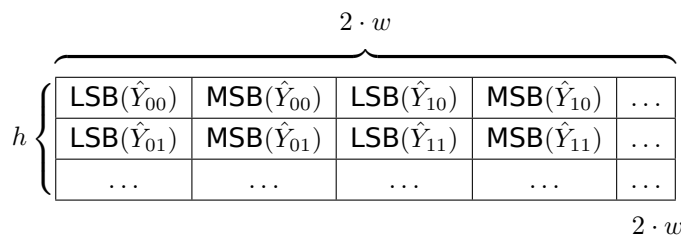

parameters

- output_format: output format, one of the following:
 - with conversion (rows are aligned to 4 byte boundaries):
 - * RGBA8 - 4 bytes per pixel 8-bit RGBA format with alpha channel set to 0xff
 - * YV12_BT601 - BT.601 limited range YV12 format
 - * YV12_BT601_FR - BT.601 full range YV12 format

- * YV12_BT709 - BT.709 limited range YV12 format
- * I420_10LE_BT601 - BT.601 limited range I420_10LE format
- * I420_10LE_BT601_FR - BT.601 full range I420_10LE format
- * I420_10LE_BT709 - BT.709 limited range I420_10LE format
- * NV12_BT601 - BT.601 limited range NV12 format
- * NV12_BT601_FR - BT.601 full range NV12 format
- * NV12_BT709 - BT.709 limited range NV12 format
- * P010_BT601 - BT.601 limited range P010 format
- * P010_BT601_FR - BT.601 full range P010 format
- * P010_BT709 - BT.709 limited range P010 format
- without conversion:
 - * Mono8 - Monochrome 8-bit
 - * Mono12 - Monochrome 12-bit unpacked
 - * Mono16 - Monochrome 16-bit
 - * BayerRG8 - Bayer Red-Green 8-bit
 - * BayerRG12 - Bayer Red-Green 12-bit unpacked
 - * BayerRG16 - Bayer Red-Green 16-bit
 - * BayerBG8 - Bayer Blue-Green 8-bit
 - * BayerBG12 - Bayer Blue-Green 12-bit unpacked
 - * BayerBG16 - Bayer Blue-Green 16-bit
 - * BayerGR8 - Bayer Green-Red 8-bit
 - * BayerGR12 - Bayer Green-Red 12-bit unpacked
 - * BayerGR16 - Bayer Green-Red 16-bit
 - * BayerGB8 - Bayer Green-Blue 8-bit
 - * BayerGB12 - Bayer Green-Blue 12-bit unpacked
 - * BayerGB16 - Bayer Green-Blue 16-bit
 - * RGB8 - Red-Green-Blue 8-bit
 - * RGB12 - Red-Green-Blue 12-bit unpacked
 - * RGB16 - Red-Green-Blue 16-bit

For format description see also [GenICam Pixel Format Naming Convention \(PFNC\) Version 2.4](#).

export_to_host

Copies data to CPU buffer, optionally converting to specified format.

JSON configuration:

```

1 {
2   "id": "export_to_host",
3   "type": "export_to_host",
4   "output_name": "out",
5   "output_format": "RGB16"
6 }
```

parameters

See parameters of [export_to_device](#) component.

histogram

Computes a histogram and exports it as an array of 32-bit integers to CPU buffer.

JSON configuration:

```

1 {
2   "id": "hist",
3   "type": "histogram",
4   "output_name": "out",
5   "output_format": "Histogram3Bayer256Int"
6 }
```

formula

$$whitepoint = bins - 1$$

$$out_{xy} = \sum_{(i,j) \in \Pi_y} I_x(in_{ij})$$

$$x \in \{0, 1, 2, \dots, whitepoint\}$$

$$y \in X$$

$$I_x(z) = \begin{cases} 0 & \frac{z}{white_level} < \frac{x}{whitepoint} \\ 1 & \frac{x}{whitepoint} \leq \frac{z}{white_level} < \frac{x+1}{whitepoint} \\ 0 & \frac{x+1}{whitepoint} \leq \frac{z}{white_level} \end{cases} \quad (a)$$

$$\Pi_y = \{(i, j) \mid i, j \in \mathbb{N}_0, i < w, j < h, (i + c_x) \bmod 2 + 2 \cdot ((j + c_y) \bmod 2) \in Y_y\} \quad (b)$$

where (w, h) are image dimensions,

and (c_x, c_y) defines image Bayer pattern shift compared to RGGGB

$$Y_V = \{0, 1, 2, 3\}, Y_R = \{0\}, Y_G = \{1, 2\}, Y_{G1} = \{1\}, Y_{G2} = \{2\}, Y_B = \{3\}$$

(a) defines whether value z falls into bin x . (b) defines pixel positions for specific color channel from X .

parameters

- offset_x (default 0)
- offset_y (default 0)
- width (optional)
- height (optional)
- output_format: output format, one of the following, where <bins> is a power of 2:
 - HistogramMono<bins>Int - $X = \{V\}$
 - Histogram3Bayer<bins>Int - $X = \{R, G, B\}$
 - Histogram4Bayer<bins>Int - $X = \{R, G1, G2, B\}$
 - HistogramRGB256Int - not yet documented
 - HistogramParade256Int - not yet documented

First 4 parameters define ROI for histogram computation, by default whole image is processed.

Image filters

Image filters must be intermediate elements in the cuda_processor pipeline (each filter must be used in connections section exactly once as dst and at least once as src).

bitdepth

Changes bit-depth of the image using zero-filling shift operation.

JSON configuration:

```

1 {
2   "id": "bitdepth",
3   "type": "bitdepth",
4   "bitdepth": 8
5 }
```

formula

$$out = in \cdot 2^{bitdepth - in_bitdepth}$$

parameters

- bitdepth (optional): output bit-depth, by default converts 10-bit format and 14-bit format to 16-bit leaving others as is

black_level

Add-multiply filter, which subtracts black level (taken from image metadata) from each pixel and then scales the result, so that maximum (white level) stays the same.

JSON configuration:

```

1 {
2   "id": "black_level",
3   "type": "black_level"
4 }
```

formula

$$out = (in - black_level) \cdot \frac{white_level}{white_level - black_level}$$

color_correction

Transforms image colors by matrix multiplying RGB color values of each pixel by specified 3x3 **color correction matrix**.

JSON configuration:

```

1 {
2   "id": "color_correction",
3   "type": "color_correction",
4   "from": "Camera",
5   "to": "Custom",
6   "matrix": [ 1.0, 0.0, 0.0,
7               0.0, 1.0, 0.0,
8               0.0, 0.0, 1.0 ]
9 }
```

formula

$$\begin{pmatrix} R_{out} \\ G_{out} \\ B_{out} \end{pmatrix} = \begin{pmatrix} M_{00} & M_{01} & M_{02} \\ M_{10} & M_{11} & M_{12} \\ M_{20} & M_{21} & M_{22} \end{pmatrix} \cdot \begin{pmatrix} R_{in} \\ G_{in} \\ B_{in} \end{pmatrix}$$

parameters

- from (default "Camera"): input color space, see description of to parameter below for possible values
- to (default "Custom"): output color space, one of the following:
 - Camera (default for from) - camera color space as specified in global cuda_processor [color/dcp_file](#) setting (valid only for from parameter)
 - Custom (default for to) - custom color space as specified in global cuda_processor [color/xyz2rgb](#) setting (valid only for to parameter)
 - ACES
 - ACEScg
 - DisplayP3
 - ProPhotoRGB
 - Rec709 - same as sRGB
 - Rec2020
- matrix (optional): color correction matrix M in row scan order, if present overrides from and to parameters

If from parameter is set to default "Camera" value, but DNG color profile is not specified, then color correction matrix defaults to identity matrix (which still can be overridden by matrix parameter).

crop

Crops the image.

JSON configuration:

```

1 {
2   "id": "crop",
3   "type": "crop",
4   "offset_x": 0,
5   "offset_y": 0,
6   "out_width": 4096,
7   "out_height": 4096
8 }
```

parameters

- out_width
- out_height
- offset_x
- offset_y

These parameters defines crop area.

demosaic

Transforms raw Bayer image into RGB image.

JSON configuration:

```

1 {
2   "id": "demosaic",
3   "type": "demosaic",
4   "algorithm": "HQLI"
5 }
```

parameters

- algorithm: algorithm to use, one of the following:
 - HQLI - High Quality Linear Interpolation, window 5×5, avg. PSNR ~36 dB for Kodak data set
 - L7 - High Quality Linear Interpolation, window 7×7, avg. PSNR ~37.1 dB (SSIM ~0.971) for Kodak data set, doesn't support 8-bit input
 - DFPD - **Directional Filtering and a Posteriori Decision**, window 11×11, avg. PSNR ~39 dB for Kodak data set
 - MG - Multiple Gradients, window 23×23, avg. PSNR ~40.5 dB for Kodak data set, doesn't support 8-bit input
-

denoise and raw_denoise

Removes noise from the image using Discrete Wavelet Transform (DWT) and thresholding. RGB images are split to Y, Cb and Cr channels for processing. Bayer images are processed as one channel, but each color plane (R, G1, G2 and B) separately.

JSON configuration for RGB images:

```

1 {
2   "id": "denoise",
3   "type": "denoise",
4   "wavelet_type": "CDF53",
5   "dwt_levels": 4,
6   "threshold_function": "GARROTE",
7   "threshold": [ 0.0, 0.0, 0.0 ],
8   "threshold_per_level": [ [ 1.0, 1.0, 1.0 ],
9                             [ 1.0, 1.0, 1.0 ],
10                            [ 1.0, 1.0, 1.0 ],
11                            [ 1.0, 1.0, 1.0 ],
12                            [ 1.0, 1.0, 1.0 ],
13                            [ 1.0, 1.0, 1.0 ],
14                            [ 1.0, 1.0, 1.0 ],
15                            [ 1.0, 1.0, 1.0 ],
16                            [ 1.0, 1.0, 1.0 ],
17                            [ 1.0, 1.0, 1.0 ],
18                            [ 1.0, 1.0, 1.0 ] ]
19 }
```

JSON configuration for Mono and Bayer images:

```

1 {
2   "id": "denoise",
3   "type": "raw_denoise",
4   "wavelet_type": "CDF53",
5   "dwt_levels": 4,
6   "threshold_function": "GARROTE",
7   "threshold": 0.0,
8   "threshold_per_level": [ 1.0, 1.0, 1.0, 1.0, 1.0, 1.0, 1.0, 1.0, 1.0, 1.0, 1.0 ←
9   ]

```

parameters

- type: one of the following, depending on the input image format:
 - denoise - use for Mono and RGB images
 - raw_denoise - use for Bayer images
- wavelet_type (default "CDF53"): wavelet type, one of the following:
 - CDF53 (default)
 - CDF97
- dwt_levels (default 4): number of DWT levels (from 1 to 11)
- threshold_function (default "GARROTE"): threshold function, one of the following:
 - GARROTE (default)
 - HARD
 - SOFT
- threshold (default 0.0): thresholds for each channel (by default image is not modified)
- threshold_per_level (default 1.0): threshold factors per wavelet level (in ascending order) for each channel (by default threshold is used as is for all levels)

exposure_indicator

Highlights under- and over-exposed image areas with blinking effect.

JSON configuration:

```

1 {
2   "id": "exposure_indicator",
3   "type": "exposure_indicator",
4   "underexposure": 0.01,
5   "middlegray": 0.18,
6   "overexposure": 0.99,
7   "halfperiod": 10
8 }

```

formula

$$out = \begin{cases} white_level \cdot T\left(\frac{in}{white_level}\right) & n \bmod (2 \cdot halfperiod) < halfperiod \\ in & n \bmod (2 \cdot halfperiod) \geq halfperiod \end{cases}$$

where n is a zero-based sequence number of the current image

$$T(x) = \begin{cases} \text{middlegray} & x \leq \text{underexposure} \\ x & \text{underexposure} < x < \text{overexposure} \\ \text{middlegray} & x \geq \text{overexposure} \end{cases}$$

parameters

- **underexposure** (default 0.01): maximum normalized (from 0 to 1) pixel value for it to be considered under-exposed
- **middlegray** (default 0.18): normalized (from 0 to 1) pixel value to use for highlighting under- and over-exposed areas
- **overexposure** (default 0.99): minimum normalized (from 0 to 1) pixel value for it to be considered over-exposed
- **halfperiod** (default 10): how many images to process before switching between highlight and pass-through modes

ffc

Add-multiply filter, which subtracts dark frame from the image and corrects shading using **flat field** image.

JSON configuration:

```

1 {
2   "id": "ffc",
3   "type": "ffc",
4   "dark_field": "darkfield-12.raw",
5   "flat_field": "flatfield-12.raw",
6   "bitdepth": 12,
7   "width": 1024,
8   "offset_x": 0,
9   "offset_y": 0
10 }
```

formula

$$D_{xy} = \text{dark}_{xy} \cdot 2^{in_bitdepth - bitdepth}$$

$$F_{xy} = \text{flat}_{xy} \cdot 2^{in_bitdepth - bitdepth}$$

$$G_{xy} = \frac{\text{white_level}}{\text{white_level} - \overline{D}_{bayer}} \cdot \frac{(F - D)_{bayer}}{F_{xy} - D_{xy}}$$

$$\text{out}_{xy} = (in_{xy} - D_{xy}) \cdot \begin{cases} \frac{1}{8} & G_{xy} < \frac{1}{8} \\ G_{xy} & \frac{1}{8} \leq G_{xy} \leq 8 \\ 8 & G_{xy} > 8 \end{cases}$$

where $_{bayer}$ means such \acute{x} and \acute{y} , that $\begin{cases} \acute{x} \bmod 2 = x \bmod 2 \\ \acute{y} \bmod 2 = y \bmod 2 \end{cases}$, or any \acute{x} and \acute{y} if image is monochrome

parameters

- **dark_field**: path to the file containing dark field image in raw 16-bit format
- **flat_field**: path to the file containing flat field image in raw 16-bit format
- **bitdepth** (optional): bit-depth of calibration files, by default the same as input bit-depth

- width (optional): width of calibration files, by default the same as input width
- offset_x (default 0)
- offset_y (default 0)

Last 2 parameters define position of the input image relative to calibration files. Last 3 parameters can be used to process cropped image without modifying the calibration files.

Note, that even if bit-depth is 8, calibration files still use 2-byte format with higher byte zeroed out.

gamma8, gamma12, gamma16

Applies gamma curve using LUT with 8-bit, 12-bit or 16-bit output. For 16-bit input 14-bit LUT is used together with linear interpolation.

JSON configuration:

```

1 {
2   "id": "gamma8",
3   "type": "gamma8",
4   "function": "gamma",
5   "linear": 0.0,
6   "power": 1.0
7 }
```

formula

$$out = (2^{out_bitdepth} - 1) \cdot \Gamma\left(\frac{in}{white_level}\right)$$

BT.709-like gamma

$$\Gamma(x) = \begin{cases} c \cdot x & x < linear \\ a \cdot x^{power} - b & x \geq linear \end{cases}$$

where a , b and c are calculated, so that $\Gamma(x)$ is smooth and passes through (0, 0) and (1, 1)

Hybrid Log-Gamma

$$\Gamma(x) = \begin{cases} \sqrt{3} \cdot x & x \leq \frac{1}{12} \\ a \cdot \ln(12 \cdot x - b) + c & x > \frac{1}{12} \end{cases}$$

$$a = 0.17883277$$

$$b = 0.28466892$$

$$c = 0.55991073$$

parameters

- function (default "gamma"): function describing the applied curve, one of the following:
 - gamma (default) - BT.709-like gamma function
 - hlg - Hybrid Log-Gamma function
- linear (default 0.0)
- power (default 1.0)

Last 2 parameters define values of corresponding variables in BT.709-like gamma formula, and thus have an effect only when function is set to gamma.

huesatmap

Applies 3D HSV LUT to the RGB image.

JSON configuration:

```
1 {
2   "id": "huesatmap",
3   "type": "huesatmap"
4 }
```

Application algorithm is described in [DNG Specification \(version 1.5.0.0\)](#), end of chapter 6 (page 88). LUT data is taken from DNG color profile specified in global `cuda_processor` `color` settings. Input data has to be linear RGB in ProPhotoRGB color space for correct results.

resizer

Scales the image using Lanczos algorithm. Aspect ratio might not be preserved.

JSON configuration:

```
1 {
2   "id": "resizer",
3   "type": "resizer",
4   "out_width": 512,
5   "out_height": 376
6 }
```

parameters

- `out_width`
- `out_height`

These parameters defines dimensions of the output image.

undistort

Corrects lens distortion using remapping operation.

JSON configuration:

```
1 {
2   "id": "undistort",
3   "type": "undistort",
4   "lens_profile": "lens_profile.json",
5   "interpolator": "linear"
6 }
```

Lens profile file format:

```

1 {
2   "distortion": {
3     "type": "radial_simple",
4     "centerX": 1920.0,
5     "centerY": 1080.0,
6     "coefficients": [ 1.0 ]
7   }
8 }

```

formula

$$r = \sqrt{(x_{in} - centerX)^2 + (y_{in} - centerY)^2}$$

$$x_{out} = centerX + L(r) \cdot (x_{in} - centerX)$$

$$y_{out} = centerY + L(r) \cdot (y_{in} - centerY)$$

polynomial radial distortion model

$$L(r) = K_0 + K_1 \cdot r + K_2 \cdot r^2 + \dots$$

parameters

- lens_profile: path to lens profile file
- interpolator (default "linear"): used interpolation algorithm, one of the following:
 - linear (default) - linear interpolation
 - cubic - cubic interpolation
 - cubic2p_bspline - two-parameter cubic filter (B=1, C=0)
 - cubic2p_catmullrom - two-parameter cubic filter (B=0, C=1/2)
 - cubic2p_b05c03 - two-parameter cubic filter (B=1/2, C=3/10)
 - super - super sampling
 - lanczos - Lanczos filtering

lens profile parameters

- type: lens distortion model, one of the following:
 - radial_simple - polynomial radial distortion model
- centerX (optional): horizontal coordinate of distortion center in pixels, center of the image by default
- centerY (optional): vertical coordinate of distortion center in pixels, center of the image by default
- coefficients: coefficients for the distortion model formula (K_0, K_1, \dots)

All output pixels mapped outside the input image are filled with black color.

white_balance

Applies white balance to the image.

JSON configuration:

```

1 {
2   "id": "wb",
3   "type": "white_balance",
4   "algorithm": "simple",
5   "comp_min": 0.0,
6   "comp_max": 1.0
7 }

```

formula**simple algorithm**

$$out_{xy} = in_{xy} \cdot gain_{\Pi(x,y)}$$

where $gain_i$ is white balance settings for input image

$i \in \{R, G, B\}$ or $i \in \{R, G1, G2, B\}$ depending on which white balance settings are provided

$$\Pi(x, y) = \Upsilon((x \bmod 2 + 2 \cdot (y \bmod 2) + c) \bmod 4)$$

where c defines image Bayer pattern shift compared to RGGB

$$\Upsilon(0) = R, \Upsilon(1) = G \text{ or } G1, \Upsilon(2) = G \text{ or } G2, \Upsilon(3) = B$$

histogram stretch algorithm

$$cut_i = off_i + \frac{comp_max - comp_min}{gain_i}$$

where off_i and $gain_i$ are white balance settings for input image

$$i \in \{R, G, B\}$$

$$out_{xy} = (2^{16} - 1) \cdot \begin{cases} comp_min \cdot \frac{in_{xy}}{white_level \cdot off_{\Pi(x,y)}} & \frac{in_{xy}}{white_level} < off_{\Pi(x,y)} \\ comp_min + gain_{\Pi(x,y)} \cdot \left(\frac{in_{xy}}{white_level} - off_{\Pi(x,y)} \right) & off_{\Pi(x,y)} \leq \frac{in_{xy}}{white_level} \leq cut_{\Pi(x,y)} \\ comp_max + \frac{1 - comp_max}{1 - cut_{\Pi(x,y)}} \cdot \left(\frac{in_{xy}}{white_level} - cut_{\Pi(x,y)} \right) & cut_{\Pi(x,y)} < \frac{in_{xy}}{white_level} \end{cases}$$

$$\Pi(x, y) = \Upsilon((x \bmod 2 + 2 \cdot (y \bmod 2) + c) \bmod 4)$$

where c defines image Bayer pattern shift compared to RGGB

$$\Upsilon(0) = R, \Upsilon(1) = G, \Upsilon(2) = G, \Upsilon(3) = B$$

parameters

- algorithm (default "simple"): algorithm to use, one of the following:
 - simple (default) - per-channel multiplication by gain value, doesn't change bit-depth
 - stretch - histogram stretch implemented using LUT with 16-bit output (for 16-bit input 14-bit LUT is used together with linear interpolation)
- comp_min (default 0.0): maximum normalized value for shadow compression section
- comp_max (default 1.0): minimum normalized value for highlights compression section

Last 2 parameters define values of corresponding variables in histogram stretch formula, and thus have an effect only when algorithm is set to stretch.

With default settings histogram stretch algorithm is equivalent to a combination of per-channel black level (offset) and simple white balance (gain).

5 IFF SDK library interface

IFF SDK provides the C library interface for managing image processing chains within the IFF control flow. The interface of SDK library is defined by `iff.h` header file in the IFF SDK package.

5.1 Functions

5.1.1 `iff_initialize()`

```
void iff_initialize(const char* config);
```

Initialize new instance of IFF framework or increment its usage count if it has already been initialized by the calling process. Should be called before any other SDK library function call. For each call of this function process must do a corresponding call of `iff_finalize()` function. If an instance of IFF framework is already initialized, parameter `config` is ignored.

Parameters:

`config` Configuration of IFF framework in JSON format.

5.1.2 `iff_finalize()`

```
void iff_finalize();
```

Decrement usage count of IFF framework instance by calling process. When usage count reaches zero, instance is released and all processing chains within this instance are destroyed.

5.1.3 `iff_log()`

```
void iff_log(const char* level, const char* message);
```

Adds a message to IFF SDK log, unless currently configured `log level` is greater than specified message severity.

Parameters:

`level` Message severity, one of the following constants: `IFF_LOG_LEVEL_DEBUG`, `IFF_LOG_LEVEL_WARNING`, `IFF_LOG_LEVEL_ERROR`, `IFF_LOG_LEVEL_INFO` (always logged).

`message` Message to be logged.

5.1.4 `iff_create_chain()`

```
iff_chain_handle_t iff_create_chain(const char* chain_config, iff_error_handler_t ↔  
on_error);
```

Create a new IFF processing chain according to passed configuration.

Parameters:

chain_config	Configuration of IFF chain to create in JSON format. See Chain description format .
on_error	Pointer to a function that is called if error occurred during processing chain lifetime. See iff_error_handler_t .

Returns:

Handle of newly created chain.

5.1.5 iff_release_chain()

```
void iff_release_chain(iff_chain_handle_t chain_handle);
```

Finalize processing chain and release all its resources.

Parameters:

chain_handle	Handle of the processing chain, returned by iff_create_chain() function.
--------------	--

5.1.6 iff_get_params()

```
void iff_get_params(iff_chain_handle_t chain_handle, const char* params, ←
    iff_result_handler_t ret_func);
```

Get values of given chain elements parameters. Can request parameters from multiple elements at once.

Parameters:

chain_handle	Handle of the processing chain, returned by iff_create_chain() function.
params	Elements parameters names to get in JSON format. See Get parameters input format .
ret_func	Pointer to a function that is called by SDK to return values of requested elements parameters. See iff_result_handler_t .

5.1.7 iff_set_params()

```
void iff_set_params(iff_chain_handle_t chain_handle, const char* params);
```

Set chain elements parameters. Can set parameters for multiple chain elements at once.

Parameters:

chain_handle Handle of the processing chain, returned by [iff_create_chain\(\)](#) function.
 params Chain elements parameters and its values to set. See [Set parameters input format](#).

5.1.8 iff_execute()

```
void iff_execute(iff_chain_handle_t chain_handle, const char* command);
```

Request execution of the specified command from the chain element.

Parameters:

chain_handle Handle of the processing chain, returned by [iff_create_chain\(\)](#) function.
 command Command to execute and its parameters if any in JSON format. See [Execute input format](#).

5.1.9 iff_set_callback()

```
void iff_set_callback(iff_chain_handle_t chain_handle, const char* name, ↔  
iff_callback_t callback);
```

Set the given function to the specified element callback.

Parameters:

chain_handle Handle of the processing chain, returned by [iff_create_chain\(\)](#) function.
 name Element callback name in the format **<element ID>/<callback name>**.
 callback Pointer to callback function. See [iff_callback_t](#).

5.1.10 iff_set_export_callback()

```
void iff_set_export_callback(iff_chain_handle_t chain_handle, const char* ↔  
exporter_id, iff_frame_export_function_t export_func, void* private_data);
```

Set the given function to the specified exporter element (see [frame_exporter](#)) as export callback, in which a pointer to the frame data will be passed from IFF SDK library to the user code.

Parameters:

chain_handle Handle of the processing chain, returned by [iff_create_chain\(\)](#) function.
 exporter_id ID of the exporter element. See [frame_exporter](#).
 export_func Pointer to export callback function. See [iff_frame_export_function_t](#).
 private_data Pointer to the user data. This pointer will be passed as parameter to export_func function with each invocation.

5.2 Structures

5.2.1 iff_image_metadata

Image metadata structure contains parameters of a specific processed image.

Structure definition:

```
typedef struct iff_wb_params
{
    float r;
    float g1;
    float g2;
    float b;
    float r_off;
    float g1_off;
    float g2_off;
    float b_off;
} iff_wb_params;

typedef struct iff_image_metadata
{
    size_t padding;

    uint32_t width;
    uint32_t height;
    uint32_t offset_x;
    uint32_t offset_y;

    uint64_t ts;
    uint64_t ntp_time;

    uint32_t black_level;
    unsigned int exposure;
    float gain;

    iff_wb_params wb;

    unsigned char sequence_id;
} iff_image_metadata;
```

Members:

padding	Image padding in bytes.
width	Image width in pixels.
height	Image height in pixels.
offset_x	Horizontal offset of ROI or crop position.
offset_y	Vertical offset of ROI or crop position.
ts	Image timestamp provided by source.
ntp_time	Image timestamp in NTP format (see RFC 5905).
black_level	Image black level.
exposure	Image exposure time in microseconds.
gain	Image gain in dB.
wb	Image white balance coefficients.
sequence_id	ID of a dispatch session within which given image was dispatched provided by source.

5.3 Types

5.3.1 iff_error_handler_t

```
typedef void(*iff_error_handler_t)(const char* element_name, int error_code);
```

Function pointer of this type must be passed to `iff_create_chain()` function when creating a new chain. IFF will call the function at the given pointer whenever an error occurs while chain is processing the image or executing a user request.

Parameters:

element_name ID of the chain element that triggered the error.
error_code Code of an error.

5.3.2 iff_result_handler_t

```
typedef void(*iff_result_handler_t)(const char* params);
```

A function pointer of this type should be passed as a parameter to the `iff_get_params()` call. IFF will call the function at the given pointer to return a JSON string containing the values of the requested parameters. This JSON string will be passed to the function as a parameter.

Parameters:

params Values of requested chain elements parameters in JSON format.

Format of the output JSON string is the same as format of input JSON string passed to `iff_set_params()` function. See [Set parameters input format](#).

5.3.3 iff_callback_t

```
typedef void(*iff_callback_t)(const char* callback_data);
```

Function pointer of this type must be passed to `iff_set_callback()` function call. This function will be set to element callback with specified name.

Parameters:

callback_data Data returned by element callback in JSON format.

5.3.4 iff_frame_export_function_t

```
typedef void(*iff_frame_export_function_t)(const void* data, size_t size, ↵  
iff_image_metadata* metadata, void* private_data);
```

Function pointer of this type must be passed to [iff_set_export_callback\(\)](#) function call. The function at the given pointer is called by exporter element when a new frame is received to send it to the client code across IFF SDK library boundaries. After this function returns, the image is released by API and is no longer valid.

Parameters:

<code>data</code>	Pointer to image data. Could be both GPU or CPU memory pointer. After export function returns, this pointer is released by IFF SDK and is no longer valid.
<code>size</code>	Size of image data in bytes.
<code>metadata</code>	Pointer to the image metadata structure. See iff_image_metadata .
<code>private_data</code>	Pointer to the user data that was passed to iff_set_export_callback() call.

6 IFF SDK configuration

When writing application using IFF SDK, as the first step you always need to initialize SDK framework.

6.1 Initializing IFF

Before the IFF SDK can be used, `iff_initialize()` has to be called from the application process. This call will perform the necessary initialization of IFF context according to provided framework configuration in JSON format.

6.2 Framework configuration format

framework configuration example:

```
1 {
2   "logfile": "",
3   "log_level": "WARNING",
4   "set_terminate": false,
5
6   "service_threads": 0,
7
8   "enable_control_interface": false,
9   "control_interface_base_url": "/chains",
10
11  "devices": [
12    {
13      "id": "cpu_dev",
14      "type": "cpu"
15    },
16    {
17      "id": "cuda_dev",
18      "type": "cuda",
19      "device_number": 0
20    }
21  ],
22
23  "services": {
24    "rtsp_server": {
25      "host": "192.168.55.1",
26      "port": 8554,
27      "mtu": 1500,
28      "listen_depth": 9,
29      "read_buffer_size": 16384,
30      "receive_buffer_size": 4194304,
31      "session_timeout": 60
32    },
33    "http_server": {
34      "host": "0.0.0.0",
35      "port": 8080,
36      "listen_depth": 9
37    }
38  }
39 }
```

common settings

- `logfile` (default `""`): log file path, if empty IFF will output log information to stdout
- `log_level` (default `"WARNING"`): minimal level of messages to report into log file, one of the following values (in the ascending order of severity):
 - `DEBUG`
 - `WARNING` (default)
 - `ERROR`
 - `FATAL`
- `set_terminate` (default `false`): whether to set terminate handler that logs unhandled C++ exceptions
- `service_threads` (default `0`): number of threads in the main framework service pool, if set to zero number of CPU cores is used
- `enable_control_interface` (default `false`): whether to enable HTTP control interface for each created chain
- `control_interface_base_url` (default `"/chains"`): base relative URL for chain control interface within HTTP server (control interface URL for each chain will be `<control_interface_base_url>/<chain ID>`)

devices

This section describes the devices used by the framework (i.e. GPU and CPU).

device parameters

- `id`: device ID
- `type`: type of the device, one of the following:
 - `cpu`
 - `cuda`
- `device_number` (default `0`): sequence number of the device (used only for CUDA devices)

services/rtsp_server

RTSP server configuration.

parameters

- `host`: server IP address (can't be `0.0.0.0`)
- `port` (default `8554`): server port
- `MTU` (default `1500`): network MTU
- `listen_depth` (default `9`): depth of the listen queue
- `read_buffer_size` (default `16384`): buffer size when reading from an UDP socket
- `receive_buffer_size` (default `4194304`): OS receive buffer size of an UDP socket
- `session_timeout` (default `60`): keep-alive timeout for a session

services/http_server

HTTP server for chain control interface configuration.

parameters

- `host` (default `"0.0.0.0"`): server IP address (can be `0.0.0.0` to listen on all addresses)
- `port` (default `8080`): server port
- `listen_depth` (default `9`): depth of the listen queue

6.3 Chain description format

IFF creates processing chains based on their description in JSON format. Since the processing chain is an directed acyclic graph, its description is a set of vertices ([Elements](#)) interconnected by edges ([Connections](#)). Thus, in order to define any processing chain, a list of elements and a list of connections between their inputs and outputs are necessary. In addition, IFF allows, if necessary, to define a list of external parameter control for each element of the chain.

Chain definition example:

```

1 {
2   "id": "main",
3
4   "elements": [
5     {
6       "id": "cam",
7       "type": "xicamera",
8       "cpu_device_id": "cpu_dev",
9       "serial_number": "XECAS1930002",
10      "image_format": "RAW8",
11      "custom_params": [
12        { "bpc": 1 },
13        { "column_fpn_correction": 1 },
14        { "row_fpn_correction": 1 },
15        { "column_black_offset_correction": 1 },
16        { "row_black_offset_correction": 1 }
17      ],
18      "exposure": 10000,
19      "fps": 30.0,
20      "gain": 0.0
21    },
22    {
23      "id": "writer",
24      "type": "dng_writer",
25      "cpu_device_id": "cpu_dev",
26      "filename_template": "{utc_time}.dng"
27    },
28    {
29      "id": "gpuproc",
30      "type": "cuda_processor",
31      "cpu_device_id": "cpu_dev",
32      "gpu_device_id": "cuda_dev",
33      "elements": [
34        { "id": "import_from_host", "type": "import_from_host" },
35        { "id": "black_level", "type": "black_level" },
36        { "id": "white_balance", "type": "white_balance" },
37        { "id": "demosaic", "type": "demosaic", "algorithm": "HQLI" },
38        { "id": "color_correction", "type": "color_correction", "matrix": [ 1.0, 0.0, 0.0, 0.0, 1.0, 0.0, 0.0, 0.0, 1.0 ] },
39        { "id": "gamma", "type": "gamma8", "linear": 0.018, "power": 0.45 },
40        { "id": "export_to_device", "type": "export_to_device", "output_format": "NV12_BT709", "output_name": "yuv" },
41        { "id": "hist", "type": "histogram", "output_format": "Histogram4Bayer256Int", "output_name": "histogram" }

```

```

42     ],
43     "connections": [
44         { "src": "import_from_host", "dst": "black_level" },
45         { "src": "black_level", "dst": "white_balance" },
46         { "src": "white_balance", "dst": "demosaic" },
47         { "src": "demosaic", "dst": "color_correction" },
48         { "src": "color_correction", "dst": "gamma" },
49         { "src": "gamma", "dst": "export_to_device" },
50         { "src": "black_level", "dst": "hist" }
51     ]
52 },
53 {
54     "id": "autoctrl",
55     "type": "awb_aec",
56     "cpu_device_id": "cpu_dev",
57     "autostart": true,
58     "aec_enabled": true,
59     "awb_enabled": true,
60     "max_exposure": 33000
61 },
62 {
63     "id": "nvenc",
64     "type": "encoder",
65     "encoder_type": "nvidia",
66     "cpu_device_id": "cpu_dev",
67     "gpu_device_id": "cuda_dev",
68     "max_processing_count": 3,
69     "codec": "H264",
70     "bitrate": 10000000,
71     "fps": 30.0,
72     "max_performance": true
73 },
74 {
75     "id": "mon",
76     "type": "sub_monitor"
77 },
78 {
79     "id": "netstream",
80     "type": "rtsp_stream",
81     "relative_uri": "/cam"
82 }
83 ],
84 "connections": [
85     { "src": "cam", "dst": "writer" },
86     { "src": "cam", "dst": "gpuproc" },
87     { "src": "gpuproc->histogram", "dst": "autoctrl", "type": "weak ←
88     " },
89     { "src": "gpuproc->yuv", "dst": "nvenc" },
90     { "src": "nvenc", "dst": "mon" },
91     { "src": "mon", "dst": "netstream" }
92 ],
93 "parametercontrol": [
94     { "origin": "autoctrl/wb_callback", "target": "cam" },
95     { "origin": "autoctrl/exposure_callback", "target": "cam" }
96 ],
97 "commandcalls": [
98     { "origin": "mon/on_new_consumer", "target": "nvenc", "execute": { ←

```

```

98     "command": "force_idr" } }
99 ]
}
```



Important

Each chain created by the same IFF SDK instance must have a unique id

6.3.1 Elements

The `elements` section of the chain description contains the configuration of the elements that make up the chain. For more information about chain elements configuration see [IFF components](#).

6.3.2 Connections

The `connections` section of the chain description defines how elements described above are linked together into the chain. There are two types of connections between chain elements: `weak` and `strong`. Weakly connected elements do not trigger their sources to start dispatching, but they do receive frames if their source has strongly connected consumers.

Each connection has the following attributes:

- `src`: ID and output name of given connection source element (element dispatching images) in one of the following formats:
 - `<src element id>` (for example `nvenc`) when referring to element's default output (usually when it has only one output)
 - `<src element id>-><output name>` (for example `gpuproc->nv12`) otherwise
- `dst`: ID and input name of given connection destination element (element receiving images) in one of the following formats:
 - `<dst element id>` (for example `nvenc`) when referring to element's default input (usually when it has only one input)
 - `<dst element id>-><input name>` (for example `nvenc->in`) otherwise
- `type` (default "strong"): type of the given connection, one of the following values:
 - `strong` (default)
 - `weak`

6.3.3 Parameter control list

The `parametercontrol` section of the chain description defines parameters control links between the elements. Parameters control links are useful when one element needs to set some parameters to another. For example in auto white balance implementation `awb_aec` component should set white balance coefficients in its `wb_callback` to the camera component.

Each connection has the following attributes:

- `origin`: ID and callback name of controlling element
- `target`: ID of controlled element

6.3.4 Command call list

The `commandcalls` section of the chain description defines command callback links between the elements. Command callback links are useful when one element needs to request command execution from another element. For example in RTSP streaming implementation `sub_monitor` component should execute `force_idr` encoder element command in its `on_new_consumer` callback.

Each connection has the following attributes:

- `origin`: ID and callback name of controlling element
- `target`: ID of controlled element
- `execute`: command description in [execute input format](#) without the element ID

6.4 Input formats of controllable interface functions

IFF chains and components inherit controllable interface through `element`. This interface allows to get and set parameters to chain components and to send commands to them. Access to this functionality in the SDK library interface is given by functions `iff_get_params()`, `iff_set_params()` and `iff_execute()`.

6.4.1 Get parameters input format

iff_get_params() input example:

```
1 {
2     "camera1": {
3         "params": [
4             "exposure",
5             "gain",
6             "wb"
7         ]
8     },
9     "encoder1": {
10        "params": [
11            "codec",
12            "fps",
13            "bitrate"
14        ]
15    }
16 }
```

Input parameter of `iff_get_params()` function is a JSON string of the format shown above. IFF allows to get parameters of multiple elements at once with one request. To get parameters of the needed chain elements, it needs to specify their IDs as first-level keys. The `params` array contains a list of the required parameters names of the corresponding element.

6.4.2 Set parameters input format

iff_set_params() input example:

```
1 {
2     "camera1": {
3         "exposure": 15,
```



```

4     "gain": 0.0,
5     "wb": {
6         "r": 1.0,
7         "g": 1.0,
8         "b": 1.0
9     }
10 },
11 "cudaprocl": {
12     "crop_positions": {
13         "offset_x": 400,
14         "offset_y": 300
15     }
16 }
17 }

```

First level keys are the IDs of elements that need to be set parameters. The element parameters have the same format as in the chain description that is passed to `iff_create_chain()` function.

For a list of supported parameters for a particular element, see [IFF components](#).

6.4.3 Execute input format

`iff_execute()` input example:

```

1 {
2     "writer1": {
3         "command": "on",
4         "args": {
5             "filename": "test.h265"
6         }
7     }
8 }

```

As input `iff_execute()` accepts a JSON string where key is ID of the chain element you want to send command to. `command` is a name of the command to be executed by this element. `args` contains names and corresponding values of the command options.

6.5 Chain control via HTTP

IFF processing chains can be controlled via HTTP interface. To enable this interface set `enable_control_interface` option to true. For HTTP server configuration and other control interface options see [Framework configuration format](#).

URL of control interface for each chain depends on value of `control_interface_base_url` option. For each chain three control URLs are created:

```

http://<HTTP_SERVER_HOST>:<HTTP_SERVER_PORT>/chains/<chain ID>/get_params
http://<HTTP_SERVER_HOST>:<HTTP_SERVER_PORT>/chains/<chain ID>/set_params
http://<HTTP_SERVER_HOST>:<HTTP_SERVER_PORT>/chains/<chain ID>/execute

```

Each of these URLs allows you to send the corresponding command to the chain:

- `get_params` - HTTP POST JSON to this URL calls `iff_get_params()` function of the corresponding chain (for JSON input format see [Get parameters input format](#))
- `set_params` - HTTP POST JSON to this URL calls `iff_set_params()` function of the corresponding chain (for JSON input format see [Set parameters input format](#))

- `execute` - HTTP POST JSON to this URL calls `iff_execute()` function of the corresponding chain (for JSON input format see [Execute input format](#))

For more details about chains control functionality see [Input formats of controllable interface functions](#) section.

6.5.1 Curl command examples

get_params example:

```
curl -d '{ "cam": { "params": [ "exposure", "gain", "wb" ] }, "nvenc": { "params": [ "codec", "fps", "bitrate" ] } }' -X POST http://127.0.0.1:8080/chains/main/get_params
```

This example shows how to get exposure, gain and wb parameters of element with ID cam and codec, fps and bitrate parameters of element with ID nvenc of chain chain1.

set_params example:

```
curl -d '{ "cam": { "exposure": 15000, "gain": 2.0 } }' -X POST http://127.0.0.1:8080/chains/main/set_params
```

This example shows how to set the camera's cam exposure and gain parameters.

execute example:

```
curl -d '{ "writer": { "command": "on", "args": { "frames_count": 1 } } }' -X POST http://127.0.0.1:8080/chains/main/execute
```

This example shows how to send command on with runtime parameter filename to writer element of chain chain1.

7 Sample applications

7.1 farsight

Most basic and general sample application is called `farsight` and is located in `samples/01_streaming` directory of IFF SDK package. It comes with example configuration file (`farsight.json`) demonstrating the following functionality:

- acquisition from XIMEA camera
- writing of raw data to DNG files
- color pre-processing on GPU:
 - black level subtraction
 - histogram calculation
 - white balance
 - demosaicing
 - color correction
 - gamma
 - image format conversion
- automatic control of exposure time and white balance
- H.264 encoding
- RTSP streaming
- HTTP control interface

7.2 imagebroker

`imagebroker` application demonstrates how to export images to the user code across IFF SDK library boundaries. Application is located in `samples/02_export` directory of IFF SDK package. It comes with example configuration file (`imagebroker.json`) providing the following functionality:

- acquisition from XIMEA camera
- color pre-processing on GPU:
 - black level subtraction
 - histogram calculation
 - white balance
 - demosaicing
 - color correction
 - gamma
 - image format conversion
- automatic control of exposure time and white balance
- image export to the client code

Additionally example code renders images on the screen using [OpenCV](#) library, which should be installed in the system (minimal required version is 4.5.2).

7.3 crowsnest

Web interface sample called `crowsnest` demonstrates the possibility to control runtime parameters of IFF SDK pipeline and preview the video stream through an ordinary web browser. It is located in `samples/03_webrtc` directory of IFF SDK package. Web application code is based on [Vue.js](#) framework. [Janus](#) server is used to convert RTSP stream (as provided by IFF SDK) to WebRTC protocol supported by modern web browsers. [nginx](#) server is a standard solution to serve the web interface and proxy connections to IFF SDK and Janus control interface. [farsight](#) sample application can be used to run a compatible IFF SDK pipeline. User interface is self-documented in "About" tab of the presented web page.

7.3.1 Installation

`linux/install.sh` installation script is provided as a reference. It was tested on Ubuntu 20.04, NVIDIA Jetson Linux (L4T) 32.7, 35.4 and 36.2. On success it prints out instructions for final setup steps.

7.3.2 Deployment of modifications

The following commands should be used to deploy changes made to web interface source code (assuming default installation configuration as described above):

```
export PATH=/opt/mrtech/bin:"$PATH"
npm run build
cp -RT dist/ /opt/mrtech/var/www/html/
```

7.4 spectraprofiler

`spectraprofiler` application implements a workflow to create DNG color profiles (DCP), that can be used together with IFF SDK. It shares most of the C++ code with [imagebroker](#) example IFF SDK application, but also includes `coloric.py` Python script for visual color target grid positioning and uses [dcamprof](#) and [Argyll CMS](#) for DCP file generation. Application is located in `samples/04_color` directory of the IFF SDK package. It comes with example configuration files (`spectraprofiler.json` and `res/coloric.json`) suited for XIMEA cameras and standard 24-patch color reference target (e.g. Calibrite ColorChecker Passport Photo 2). See `linux` and `windows` directories for helper scripts to install required dependencies (e.g. [OpenCV](#) library). Operation is controlled using a keyboard:

- 1 decreases exposure
- 2 increases exposure
- Tab captures an image and starts the profile generation procedure (further instructions are shown on the screen)

7.5 streamadapter

`streamadapter` application demonstrates how to export images to the [GStreamer](#) pipeline from IFF SDK. Application is located in `samples/05_gstreamer` directory of IFF SDK package. It comes with example configuration file (`streamadapter.json`) providing the following functionality:

- acquisition from XIMEA camera
- color pre-processing on GPU:

- black level subtraction
- histogram calculation
- white balance
- demosaicing
- color correction
- gamma
- image format conversion
- automatic control of exposure time and white balance
- image export to the client code

7.5.1 Usage

GStreamer pipeline description is passed through command line arguments, with `streamadapter` acting as a source. For example, each incoming image can be dumped to a separate file with this command:

```
./streamadapter ! multifilesink
```

7.6 lensprofiler

`lensprofiler` application implements a workflow to create lens profiles, that can be used together with IFF SDK. It shares most of the C++ code with `imagebroker` example IFF SDK application, but also includes `ldc.py` Python script for chessboard target auto-detection and radial lens distortion model estimation, which is based on the source code provided with [Algebraic Lens Distortion Model Estimation](#) article by Luis Alvarez, Luis Gomez, and J. Rafael Sendra published in [Image Processing On Line](#) journal. Application is located in `samples/06_lens` directory of the IFF SDK package. It comes with example configuration files (`lensprofiler.json` and `res/ldc.json`) suited for XIMEA cameras and standard 10x7 chessboard target (such as included `res/chessboard.png`). See `linux` and `windows` directories for helper scripts to install required dependencies (e.g. [OpenCV](#) library). Operation is controlled using a keyboard:

- 1 decreases exposure
- 2 increases exposure
- Tab captures an image and starts the profile generation procedure (further instructions are shown on the screen)

A Changelog

A.1 Version 1.9

- Added [undistort](#) filter to [cuda_processor](#) component (available only on Linux, Windows support to come later).
- Added [lensprofiler](#) distortion estimation tool to sample applications.
- Added [streamadapter](#) GStreamer integration sample.
- Introduced auto-gain functionality to [awb_aec](#) component.
- Replaced `wait_limit` parameter with `ctrl_latency` in [awb_aec](#) component.
- Added `linear_gain` parameter to [v4l2cam](#) component.
- Simplified usage of [cuda_processor](#) export adapters (`export_to_devmem` and `export_to_hostmem` were merged into `export_to_device` and `export_to_host` respectively).
- Enhanced rendering code in [imagebroker](#) sample application, decreasing CPU load and latency.
- Expanded [encoder](#) component functionality to support encoding of Mono16 images with 10-bit H265 codec on NVIDIA Jetson platform.
- Introduced possibility to set white balance as light source temperature to all source components (except `rtsp_source`).
- Various minor bug fixes and documentation improvements.

A.2 Version 1.8.1

- Enhanced compatibility of [genicam](#) component with various machine vision camera vendors (Basler, LUCID and XIMEA cameras were tested).
- Improved reliability of image metadata produced by [genicam](#) component in case of runtime modification of exposure time or gain (e.g. by [awb_aec](#) component).
- Improved detection of GigE Vision camera disconnection by [genicam](#) component.

A.3 Version 1.8

- Added [exr_writer](#), [fps_limiter](#), [gamma](#), [highlight_recovery](#), [packer](#) and [resizer](#) components.
- Added [exposure_indicator](#), [huesatmap](#), [denoise](#) and [raw_denoise](#) filters to [cuda_processor](#) component.
- Added [spectraprofiler](#) color profiling tool to sample applications.
- Introduced color profile support to [cuda_processor](#) and [xiprocessor](#) components.
- Introduced multi-render functionality to [imagebroker](#) sample application and improved its overall performance.
- Expanded NVIDIA Jetson Linux (L4T) support up to version 36.
- Fixed video artifacts in [encoder](#) output on NVIDIA Jetson Orin platform.
- Improved compatibility of [genicam](#) component with various GenICam cameras.

- Added `black_level` and `max_buffers_queue_size` parameters to `genicam` component.
- Added possibility to change `ev_correction` parameter of `awb_aec` component at runtime.
- Added new parameters (tags) to `dng_writer` component.
- Added support for 16-bit RGB formats to `xicamera` and `xiprocessor` components.
- Enhanced filename template parameter in `raw_frame_player`, `frames_writer` and `dng_writer` components.
- Renamed `cam_ts` metadata field to `src_ts` in `metadata_saver` and `raw_frame_player` components.
- Fixed output directory path calculation in `frames_writer` and `dng_writer` components in case of empty `base_directory` parameter and non-empty `subdirectory` parameter in `on` command.
- Fixed auto-start functionality in some sinks.
- Fixed hang on exit in case some sinks are still on.
- Corrected default value of `direct_io` parameter in `files_writer` component documentation.
- Various minor bug fixes and documentation improvements.

A.4 Version 1.7

- Added `v4l2cam` component.
- Migrated to new NVENC presets in `encoder` component to ensure compatibility with future releases of NVIDIA GPU drivers. Support for old presets is to be removed by NVIDIA in 2024 starting with driver version R550. `config_preset` and `rc_mode` parameters may have to be adjusted (and new `preset_tuning` and `multypass` parameters set) according to [NVENC Preset Migration Guide](#).
- Various bug fixes.

A.5 Version 1.6

- Expanded NVIDIA Jetson Linux (L4T) support up to version 35, bringing capability to run on NVIDIA Jetson Orin modules.
- Fixed detection of newly connected cameras in `xicamera` source component.

A.6 Version 1.5

- Added `crowstest` web interface sample.
- Added `metadata_exporter` component.

A.7 Version 1.4

- Added `genicam` component.
- Added support for 12-bit packed input formats to `cuda_processor`.
- Expanded NVIDIA GPU support up to Ada Lovelace architecture (compute capability 8.x). GPU driver update may be required after upgrading to this IFF SDK version.
- Added `set_terminate` parameter to framework configuration format.
- Fixed documentation of trigger-related features.
- Various bug fixes and minor improvements.

A.8 Version 1.3

- Added [logging function](#) to the C library interface.
- Enhanced [auto white balance](#) algorithm to better handle under- and over-exposure.
- Fixed writing of non-square TIFF/DNG files in [dng_writer](#).
- Fixed compatibility of [RTSP stream](#) with WebRTC standard.
- bitrate parameter of [encoder](#) component can now be modified at runtime.
- Added `repeat_spspps`, `profile` and `level` parameters to [encoder](#) component.
- Added `force_idr` command to [encoder](#) component.
- Added [sub_monitor](#) component.
- Added [commandcalls](#) section to the chain description format.
- Added `session_timeout` parameter to [rtsp_server](#) settings.
- Other minor enhancements and bug fixes.

A.9 Version 1.2

- Added [Chain control via HTTP](#).
- Incompatible change: [Framework configuration format](#) used for `iff_initialize()` call is now a value (JSON object) of what previously was `iff` top-level key.

A.10 Version 1.1

No functional changes, only documentation update.

A.11 Version 1.0

Initial release.

B License notices

AVIR

IFF SDK uses AVIR library under the [MIT License](#).

Copyright (c) 2015-2021 Aleksey Vaneev

Permission is hereby granted, free of charge, to any person obtaining a copy of this software and associated documentation files (the "Software"), to deal in the Software without restriction, including without limitation the rights to use, copy, modify, merge, publish, distribute, sublicense, and/or sell copies of the Software, and to permit persons to whom the Software is furnished to do so, subject to the following conditions:

The above copyright notice and this permission notice shall be included in all copies or substantial portions of the Software.

THE SOFTWARE IS PROVIDED "AS IS", WITHOUT WARRANTY OF ANY KIND, EXPRESS OR IMPLIED, INCLUDING BUT NOT LIMITED TO THE WARRANTIES OF MERCHANTABILITY, FITNESS FOR A PARTICULAR PURPOSE AND NONINFRINGEMENT. IN NO EVENT SHALL THE AUTHORS OR COPYRIGHT HOLDERS BE LIABLE FOR ANY CLAIM, DAMAGES OR OTHER LIABILITY, WHETHER IN AN ACTION OF CONTRACT, TORT OR OTHERWISE, ARISING FROM, OUT OF OR IN CONNECTION WITH THE SOFTWARE OR THE USE OR OTHER DEALINGS IN THE SOFTWARE.

Boost

IFF SDK uses Boost C++ libraries under the [Boost Software License, Version 1.0](#).

{fmt}

IFF SDK uses {fmt} library under the [MIT License](#).

GenICam®

GenICam edition of IFF SDK uses GenICam libraries under the GenICam license.

Copyright (c) EMVA and contributors (see source files)

All rights reserved

Redistribution and use in source and binary forms, without modification, are permitted provided that the following conditions are met:

~ Redistributions of source code must retain the above copyright notice, this list of conditions and the following disclaimer.

~ Redistributions in binary form must reproduce the above copyright notice, this list of conditions and the following disclaimer in the documentation and/or other materials provided with the distribution.

~ Neither the name of the GenICam standard group nor the names of its contributors may be used to endorse or promote products derived from this software without specific prior written permission.

THIS SOFTWARE IS PROVIDED BY THE COPYRIGHT HOLDERS AND CONTRIBUTORS "AS IS" AND ANY EXPRESS OR IMPLIED WARRANTIES, INCLUDING, BUT NOT LIMITED TO, THE IMPLIED WARRANTIES OF MERCHANTABILITY AND FITNESS FOR A PARTICULAR PURPOSE ARE DISCLAIMED. IN NO EVENT SHALL THE COPYRIGHT OWNER OR CONTRIBUTORS BE LIABLE FOR ANY DIRECT, INDIRECT, INCIDENTAL, SPECIAL, EXEMPLARY, OR CONSEQUENTIAL DAMAGES (INCLUDING, BUT NOT LIMITED TO, PROCUREMENT OF SUBSTITUTE GOODS OR SERVICES; LOSS OF USE, DATA, OR PROFITS; OR BUSINESS INTERRUPTION) HOWEVER CAUSED AND ON ANY THEORY OF LIABILITY, WHETHER IN CONTRACT, STRICT LIABILITY, OR TORT (INCLUDING NEGLIGENCE OR OTHERWISE) ARISING IN ANY WAY OUT OF THE USE OF THIS SOFTWARE, EVEN IF ADVISED OF THE POSSIBILITY OF SUCH DAMAGE.

The GNU C Library

Linux version of IFF SDK uses glibc library under the [GNU Lesser General Public License](#).

The GNU Compiler Collection

Linux version of IFF SDK uses libgcc and libstdc++ libraries under the [GNU General Public License](#) plus the [GCC Runtime Library Exception](#).

JSON for Modern C++

IFF SDK and sample applications use JSON for Modern C++ library under the [MIT License](#).

Copyright © 2013-2022 [Niels Lohmann](#)

Permission is hereby granted, free of charge, to any person obtaining a copy of this software and associated documentation files (the "Software"), to deal in the Software without restriction, including without limitation the rights to use, copy, modify, merge, publish, distribute, sublicense, and/or sell copies of the Software, and to permit persons to whom the Software is furnished to do so, subject to the following conditions:

The above copyright notice and this permission notice shall be included in all copies or substantial portions of the Software.

THE SOFTWARE IS PROVIDED "AS IS", WITHOUT WARRANTY OF ANY KIND, EXPRESS OR IMPLIED, INCLUDING BUT NOT LIMITED TO THE WARRANTIES OF MERCHANTABILITY, FITNESS FOR A PARTICULAR PURPOSE AND NONINFRINGEMENT. IN NO EVENT SHALL THE AUTHORS OR COPYRIGHT HOLDERS BE LIABLE FOR ANY CLAIM, DAMAGES OR OTHER LIABILITY, WHETHER IN AN ACTION OF CONTRACT, TORT OR OTHERWISE, ARISING FROM, OUT OF OR IN CONNECTION WITH THE SOFTWARE OR THE USE OR OTHER DEALINGS IN THE SOFTWARE.

The class contains the UTF-8 Decoder from Bjoern Hoehrmann which is licensed under the [MIT License](#) (see above). Copyright © 2008-2009 [Björn Hoehrmann](#) <bjorn@hoehrmann.de>

The class contains a slightly modified version of the Grisu2 algorithm from Florian Loitsch which is licensed under the [MIT License](#) (see above). Copyright © 2009 [Florian Loitsch](#)

The class contains a copy of [Hedley](#) from Evan Nemerson which is licensed as [CC0-1.0](#).

Microsoft Visual C++ Runtime

Windows version of IFF SDK uses Microsoft Visual C++ Runtime libraries under the [Microsoft Software License Terms](#).

NVIDIA® CUDA® Toolkit

CUDA edition of IFF SDK uses CUDA Toolkit under the [EULA](#).

OpenEXR

IFF SDK uses OpenEXR and Imath libraries under the [BSD-3-Clause License](#).

Copyright (c) Contributors to the OpenEXR Project. All rights reserved.

Redistribution and use in source and binary forms, with or without modification, are permitted provided that the following conditions are met:

1. Redistributions of source code must retain the above copyright notice, this list of conditions and the following disclaimer.
2. Redistributions in binary form must reproduce the above copyright notice, this list of conditions and the following disclaimer in the documentation and/or other materials provided with the distribution.
3. Neither the name of the copyright holder nor the names of its contributors may be used to endorse or promote products derived from this software without specific prior written permission.

THIS SOFTWARE IS PROVIDED BY THE COPYRIGHT HOLDERS AND CONTRIBUTORS "AS IS" AND ANY EXPRESS OR IMPLIED WARRANTIES, INCLUDING, BUT NOT LIMITED TO, THE IMPLIED WARRANTIES OF MERCHANTABILITY AND FITNESS FOR A

PARTICULAR PURPOSE ARE DISCLAIMED. IN NO EVENT SHALL THE COPYRIGHT HOLDER OR CONTRIBUTORS BE LIABLE FOR ANY DIRECT, INDIRECT, INCIDENTAL, SPECIAL, EXEMPLARY, OR CONSEQUENTIAL DAMAGES (INCLUDING, BUT NOT LIMITED TO, PROCUREMENT OF SUBSTITUTE GOODS OR SERVICES; LOSS OF USE, DATA, OR PROFITS; OR BUSINESS INTERRUPTION) HOWEVER CAUSED AND ON ANY THEORY OF LIABILITY, WHETHER IN CONTRACT, STRICT LIABILITY, OR TORT (INCLUDING NEGLIGENCE OR OTHERWISE) ARISING IN ANY WAY OUT OF THE USE OF THIS SOFTWARE, EVEN IF ADVISED OF THE POSSIBILITY OF SUCH DAMAGE.

xiAPI

XIMEA edition of IFF SDK uses XIMEA Application Programming Interface (xiAPI) under the License For Customer Use of XIMEA Software.

Copyright © 2002-2024 XIMEA